



Smurvörur og fylgihlutir

Efnisyfirlit

			Bls.
Ac áfylling	83	Rúðuvökvi	83
Adblue fyrir bíla og vinnuvélar	30	Sea foam Spíssahreinsir og fleira	89
Bremsuvökvar og bremsuféiti	80-82	Sjálfskiptingar viðgerðarefni	86
Demparaolía	68	Sjálfskiptivökvar	46-56
Fleygafeiti	109-110		
Fluid Film	112	Slátturvélarolía	73
Frostlögur	74-79	Sleðaolía MS2-MS220	67
Gírolía 10W , 30W, 80W	44-45	Smurkerfi Lincoln og nipplar	116-133
Gírolía Castol BM320	114	Smurkoppur	134-137
Gírolía Dráttarvélar f/blautbremsur	31-34	Smurkönnur	142
Gírolía Fólksbílar og fl. 75W - 75W/140	35-40	Smurolía Dráttarvélar 10W/30 S.T.O.U	28
Gírolía Fólksbílar og fl. 80W - 80W/90	41-42	Smurolía Dráttarvélar 10W/40 S.T.O.U	29
Gírolía Fólksbílar og fl. 85W - 85W/140	43	Smurolía Dráttarvélar 15W/40 S.T.O.U	30
Gírolía Matvæla	111		
Gírolía Total EP 68-680	112	Smurolía Flugvélar 15W/50	27
Gírolía Total SH 150-1000	113	Smurolía Fólksbílar 0W/16	8
Gírolía Total XEP 220-680	114	Smurolía Fólksbílar 0W/20	8-11
Gírolía Þyrlur	110	Smurolía Fólksbílar 0W/30	12-14
		Smurolía Fólksbílar 0W/40	14
Glussi HD10W	57	Smurolía Fólksbílar 5W/20	15-16
Glussi 15-22	58	Smurolía Fólksbílar 5W/30	1-6
Glussi 32	58-60	Smurolía Fólksbílar 5W/40	16-17
Glussi 46	61-63	Smurolía Fólksbílar 5W/50	18
Glussi 68	64-66	Smurolía Fólksbílar 10W/40	6-7
Glussi 100-460	66-67	Smurolía Fólksbílar 10W/60	18
Glussi Hitachi	68	Smurolía Fólksbílar 15W/50	17
Háhita Koppafeiti	108	Smurolía Fólksbílar 20W/50	18
Hreinsiefni Valvoline	86-88		
		Smurolía Vörub. og vinnuvél 5W/30	19
		Smurolía Vörub. og vinnuvél 5W/40	19
		Smurolía Vörub. og vinnuvél 10W/30	20-21
		Smurolía Vörub. og vinnuvél 10W/40	22-24
		Smurolía Vörub. og vinnuvél 15W/40	24-27
		Smurskammtarabox	151
		Smursprautur, stútar og nálar	138-142
		Stýrisvökvar	56-57
		Tectyl, Undirvagns sprej	84-85
		Tjakkaolía	63
		Trehtar	143
		Tunnudæla	30
		Tvígengisolíur	73
		Utanborðsmótorsolíur	73
		WD-40 Efnavörur	93-94
Loftpressuolía	68		
Loftverkfæraolía	68		
Matvælafeiti	104-107		
Motip Efnavörur ýmiskonar	90-92		
Mótorhjólaolíur og feiti	69-72		
Olíudælur og fylgihlutir	152-167		
Olíustaðlar	167-172		
Perma smurhylki og fylgihlutir	144-150		



Smurólía - Fólksbílar

HYBRID



5W/30 C2

Full synthetic

Heiti

Vörunúmer

HYBRID C2 5W-30 1 LTR

044 892443

HYBRID C2 5W-30 5 LTR

044 892444

HYBRID C2 5W-30 20 LTR

044 892445

Performance levels

ACEA: C2

API: SP

API: SN



Smurólía - Fólksbílar

HYBRID



5W/30 C3

Full synthetic

Heiti

Vörunúmer

HYBRID C3 5W-30 1 LTR

044 892447

HYBRID C3 5W-30 5 LTR

044 892448

Performance levels

ACEA: C3

API: SP

API: SN



Handþvottaefni frá Valvoline



Heiti

Vörunúmer

Handþvottakrem gult 4,5kg

044 59020

Handpumpa fyrir Valvoline

044 91393

Veggstandur fyrir Valvoline handhr.

044 825162

Smurólía - Fólksbílar

5/30 Olía longlife Full synthetic



Heiti	Vörunúmer
Full synthetic	
SYNPOWER XL-III C3 5W-30 1 LTR	044 872372
SYNPOWER XL-III C3 5W-30 5 LTR	044 872375
SYNPOWER XL-III C3 5W-30 20 LTR	044 872376
SYNPOWER XL-III C3 5W-30 208 LTR	044 872796

Approvals

BMW LL-04
MB-Approval 229.51
Porsche C30
VW 50400/50700*
* can be used where VW 50101, 50200, 50301, 50500, 50300, 50600, 50601 are specified.

Performance levels

ACEA C3
API: SN
MB-229.31
VW TL 52195
recommended for use where Fiat 9.55535 S3 is specified (Fiat petrol engines only)

Smurólía - Fólksbílar

5/30 Olía longlife Full synthetic



Heiti	Vörunúmer
Full synthetic	
ALL-CLIMATE C2/C3 5W/30 1 LTR	044 881924
ALL-CLIMATE C2/C3 5W/30 5 LTR	044 881925
ALL-CLIMATE C2/C3 5W/30 208 LTR	044 881923

Performance levels

ACEA C2, C3
API: SN

Suitable for engines with Diesel Particle Filter (DPF), Gasoline Catalytic Converter systems (GCC) or Three Way Catalytic Converter (TWC) where ACEA C2 or C3 specification is prescribed, such as Toyota, Hyundai, Kia, Nissan, etc.

5/30 Olía fyrir bíla sem ekki eru í ábyrgð

Smurólía - Fólksbílar

5/30 Olía Full synthetic



Heiti	Vörunúmer
MAXLIFE 5W-30 1 LTR	044 872371
MAXLIFE 5W-30 5 LTR	044 872794
Fyrir benzín og dísel bifreiðar.	

Performance levels

ACEA A3/B3, A3/B4
MB-229.3
VW 50200/50500



Smurólía - Fólksbílar

5W/30 FE



Heiti

Vörunúmer

SYNPOWER FE 5W-30 1 L
SYNPOWER FE 5W-30 5 L
SYNPOWER FE 5W-30 20 L

044 872551
044 872552
044 872553

Performance levels

ACEA A1/B1
ACEA A5/B5
API: SL/CF
Jaguar Land Rover STJLR 03.5003
Renault RN0700
Recommended for in-warranty service fill where Ford WSS-M2C913-D is required.
Suitable for use where Ford WSS-M2C913-A, B, C are specified.
Ford diesel engines (Except Ford Ka TDCi 2009 > and Galaxy 1.9 TDi 2000-2006).



Smurólía - Fólksbílar

5W/30 MST



Heiti

Vörunúmer

SynPower MST C3 5W/30 1 LTR
SynPower MST C3 5W/30 5 LTR

044 872596
044 874308

Approvals

BMW LL-04
GM Dexos 2 (D23503AC103)
MB-Approval 229.31
MB-Approval 229.51
MB-Approval 229.52
VW 50500/50501

Performance levels

ACEA C2, C3
API: SN/CF
Recommended for use where Fiat 9.5535.S3 is specified (Fiat petrol engines only).



Smurólía - Fólksbílar

5W/30 C4

Full synthetic



Heiti

Vörunúmer

SynPower MST C4 5W-30 1 LTR
SynPower MST C4 5W-30 5 LTR
SynPower MST C4 5W-30 20 LTR

044 872770
044 872771
044 872772

Approvals

MB-Approval 226.51
Renault RN0720

Performance levels

ACEA C4
Meets requirements of some models of:
Nissan*
Suzuki*

* check owners manual before use



Smurólía - Fólksbílar

5W/30



Heiti

Vörunúmer

Smurólía 5W/30 Navi Guard Elite
205 ltr

216020

Navi-Guard Elite Synthetic Blend GF5 SN+ Engine Oils are available in two multi-viscosity grades: SAE 5W-20 and 5W-30. These two grades contain friction-reducing additives. Meet or Exceeds: Ford WSS-M2C945-A, Ford WSS-M2C946-A, GM 6094M, and Chrysler MS 6395 specifications.

elf Smurólía - Fólksbílar **5W/30 SXR**

Heiti	Vörunúmer
Smurólía 5W-30 Evolution 900 SXR 1 Ltr	213888
Smurólía 5W-30 Evolution 900 SXR 5 Ltr	213894
Smurólía 5W-30 Evolution 900 SXR 208 Ltr	194782

PERFORMANCES

International specifications ACEA : A5/B5
API: SL/CF

OEMs specifications RENAULT RN0700(except 2.0 16V Renault Sport, 2.0 T Renault Sport, V6 Renault Sport)
FORD WSS-M2C913-D (back-compatible FORD WSS-M2C913-C)
JAGUAR STJLR 03.5003

elf Smurólía - Fólksbílar með Díselvélar **5W/30 C4** Full-Tech FE
Fyrir bifeiðar með sótagnasíur. Heiti Vörunúmer

Smurólía 5W-30 Evolution Full-Tech 1 ltr Full-Tech FE	213933
Smurólía 5W-30 Evolution Full-Tech 5 ltr Full-Tech FE	213935

PERFORMANCES

International specifications ACEA : C4, level of performance C3

OEMs approvals RENAULT RN0720
MERCEDES-BENZ MB-Approval 226.51

elf Smurólía - Fólksbílar **5W/30 C3** Full-Tech LLX
Bensín og Dísel vélar Heiti Vörunúmer

Heiti	Vörunúmer
Synthetic	
Smurólía 5W/30 Evolution Full-Tech 1 ltr Full-Tech LLX	213905
Smurólía 5W/30 Evolution Full-Tech 5 ltr Full-Tech LLX	213920
Smurólía 5W/30 Evolution Full-Tech 208 ltr Full-Tech LLX	194795

PERFORMANCES

International specifications ACEA C3

OEMs approvals VOLKSVAGEN VW 504.00 / 507.00
PORSCHE C30
BMW BMW LL-04
MERCEDES BENZ MB 229.51 (Backward compatible to MB-approval 229.31)

elf Smurólía - Fólksbílar **5W/30 C3** R-Tech Elite
Bensín og Dísel vélar Heiti Vörunúmer

Smurólía 5W/30 Evolution R-Tech 1 ltr R-Tech Elite	217612
---	--------

ACEA C3, RENAULT RN17, RN 0700, RN 0710



Smurólía - Fólksbílar

5W/30 C1



Heiti

Vörunúmer

Smurólía 5W/30 Quartz Ineo C1

214104

- JAGUAR LAND ROVER : STJLR.03.5005
- Meets the requirements of FORD WSS-M2C934-B and WSS-M2C934-A



Smurólía - Fólksbílar

5W/30 Longlife C3

Bensín og dísel vélar

Heiti

Vörunúmer



Smurólía 5W-30 Quartz Ineo Longlife

213818

1 ltr

Smurólía 5W-30 Quartz Ineo Longlife

213819

5 ltr

Smurólía 5W-30 Quartz Ineo Longlife

181710

20 ltr

Smurólía 5W-30 Quartz Ineo Longlife

180858

208 ltr



- ACEA C3
- API SN/CF



- VW 504.00/507.00
- BMW LL-04
- MB-Approval 229.51
- PORSCHE C30
- Isuzu Recommended Lubricant (2020)



Smurólía - Fólksbílar

5W/30 C2

Bensín og dísel vélar

Heiti

Vörunúmer



Smurólía 5W-30 Quartz Ineo ECS

213683

5 ltr

Smurólía 5W-30 Quartz Ineo ECS

151260

208 ltr

- ACEA C2
- PSA B71 2290
- Meets the requirements of:
 - FIAT 9.55535-S1
 - IVECO 18-1811 SC1
- Suitable for TOYOTA.



Handþvottakrem frá Tub o' Scrub

Heiti

Vörunúmer



Handþvottakrem Tub O Scrub 18oz

102 TS18

Inniheldur Valhnetu skel

Fjarlægir olíu, feiti og þykkan skít án vatns.

Inniheldur lanólín, Aloe og Vítamín E

Niðurbrjótanlega formúla sem stíflast ekki í niðurföllum.



Smurólía - Fólksbílar

5W/30 C2, C3



- ACEA C2 & C3
- API SN/CF

Heiti	Vörunúmer
Smurólía 5W-30 Quartz Ineo MDC 1 ltr	214030
Smurólía 5W-30 Quartz Ineo MDC 5 ltr	214031

- MERCEDES-BENZ: MB-Approval 229.52
- GENERAL MOTORS: Official dexos2™ license: Official Dexos 2™ license: GB2F0312070 Meets the latest technical requirements of GM engines (Opel, Vauxhall, Chevrolet).
- OPEL / VAUXHALL OV0401547
- HYUNDAI – KIA: Meets the requirements of Hyundai Kia



Smurólía - Fólksbílar

10W/40



Heiti	Vörunúmer
PART SYNTHETIC DURABLEND	
ALL-CLIMATE 10W/40 1 LTR	044 872774
ALL-CLIMATE 10W/40 5 LTR	044 872776
ALL-CLIMATE 10W/40 20 LTR	044 872777
ALL-CLIMATE 10W/40 208 LTR	044 798339

Performance levels

ACEA A3/B4
API: SL/CF
Recommended by Valvoline for use in engines specifying VW 50500, VW 50101 or MB-229.1
Recommended for use where Fiat 9.55535.D2 and G2 is specified.



Smurólía - Fólksbílar

10W/40



Heiti	Vörunúmer
SYNTHETIC TECHNOLOGY	
MAXLIFE SAE 10W/40 1 LTR	044 872295
MAXLIFE SAE 10W/40 5 LTR	044 872297
MAXLIFE SAE 10W/40 20 LTR	044 872328

Performance levels

ACEA A3/B3, A3/B4
API: SM, SN/CF
MB-229.3
PSA B71 2300
Renault RN0700/0710
VW 50200/50500
Recommended for use where Fiat 9.55535.G2 or D2 is specified.

Fyrir mikið ekna bíla.



Smurólía - Fyrir fornbíla.

10W/40



SAE 10w/40
Fyrir fornbíla

Heiti	Vörunúmer
CLASSIC OLÍA M/ ZDDP 10W/40 Zink innhald 2200 ppm	311 V67SL-5



Smurólía - Fólksbílar



10W/40

Heiti	Vörunúmer
Semi- synthetics	
Smurólía 10W/40 Evolution 700 STI 1 ltr	214125
Smurólía 10W/40 Evolution 700 STI 5 ltr	214124
Smurólía 10W/40 Evolution 700 STI 20 ltr	201543
Smurólía 10W/40 Evolution 700 STI 208 ltr	201542

PERFORMANCES

International specifications

ACEA : A3/B4
API : SN/CF

OEMs approvals

VOLKSVAGEN VW 501.01 / 505.00
MERCEDES BENZ MB-Approval 229.1
RENAULT RN0700/0710

Meets the requirements of : FIAT 9.55535-G2



Smurólía - Fólksbílar

Bensín og dísel vélar



10W/40

Heiti	Vörunúmer
Smurólía 10w-40 Quartz 7000 C1 5 ltr	214109

ACEA A3/B4
API SN/CF
APPROVED BY:
PSA B71 2300 (backward compatible
PSA B71 2294)
MB-Approval 229.3
VW 501.01/505.00
RENAULT RN 0700/0710
MEET THE REQUIREMENTS:
FIAT 9.55535-G2



Oliuklútar



HEITI	VÖRUNÚMER
Uppsogsmottur alhliða 50x40cm 100 stk í kassa. Gráar	066 SAP01
Uppsogsmottur efnavöru 50x40cm 100 stk í kassa. Gular	CPRM100-80



Smurólía fyrir fólksbíla

0W/16

Bensín



Heiti

Vörunúmer

Smurólía 0W/16 Quartz 9000 X.F.XT
5 Ltr

225560

KEY DATA

LIGHT VEHICLE RANGE



GASOLINE ENGINE OIL
SAE 0W-16
ADVANCED SYNTHETIC TECHNOLOGY
XTRA FUEL ECONOMY



INTERNATIONAL STANDARDS

- API SP
- ILSAC GF-6B

MANUFACTURER APPROVALS¹

- Suitable for Toyota, Honda, Nissan, Mitsubishi

¹Please refer to car owner's manual



Smurólía fyrir fólksbíla

0W/20

Bensín



Heiti

Vörunúmer

Smurólía 0W/20 Quartz 9000
1 ltr Future GF-6

223758

KEY DATA

LIGHT VEHICLE RANGE



GASOLINE ENGINE OIL
SAE 0W-20
ADVANCED SYNTHETIC TECHNOLOGY
FUEL ECONOMY



INTERNATIONAL STANDARDS

- API SP
- ILSAC GF-6A



Smurólía fyrir Mazda fólksbíla

0W/20

Bensín



Heiti

Vörunúmer

Smurólía 0W/20 Mazda Original
1 ltr Supra-x

216247

API SN ILSac GF5

MAZDA Original Oil Supra X 0W-20 has been developed for SKYACTIV petrol engines.

This oil uses a synthetic lubricant of the latest technology, reduces fuel consumption and improves engine performance.

This MAZDA oil is suitable for Mazda SKYACTIV petrol engines, which recommend a viscosity of 0W-20.

API SN ILSac GF5





elf Smurolía fyrir fólksbíla 0W/20

	Vörunúmer						
	<table border="1" style="width: 100%; border-collapse: collapse;"> <thead> <tr> <th style="width: 50%; text-align: left;">Heiti</th> <th style="width: 50%;"></th> </tr> </thead> <tbody> <tr> <td>Smurolía 0W-20 Evolution R-tech 1 ltr Elite FE</td> <td style="text-align: right;">219227</td> </tr> <tr> <td>Smurolía 0W-20 Evolution R-tech 5 ltr Elite FE</td> <td style="text-align: right;">219231</td> </tr> </tbody> </table> <p>ACEA C5, RENAULT RN17 FE</p>	Heiti		Smurolía 0W-20 Evolution R-tech 1 ltr Elite FE	219227	Smurolía 0W-20 Evolution R-tech 5 ltr Elite FE	219231
Heiti							
Smurolía 0W-20 Evolution R-tech 1 ltr Elite FE	219227						
Smurolía 0W-20 Evolution R-tech 5 ltr Elite FE	219231						

TOTAL Smurolía fyrir fólksbíla 0W/20
Bensín og dísel

	Vörunúmer						
	<table border="1" style="width: 100%; border-collapse: collapse;"> <thead> <tr> <th style="width: 50%; text-align: left;">Heiti</th> <th style="width: 50%;"></th> </tr> </thead> <tbody> <tr> <td>Smurolía 0W/20 Quartz Ineo Xtra EC5 1 ltr</td> <td style="text-align: right;">225943</td> </tr> <tr> <td>Smurolía 0W/20 Quartz Ineo Xtra EC5 5 ltr</td> <td style="text-align: right;">225944</td> </tr> </tbody> </table>	Heiti		Smurolía 0W/20 Quartz Ineo Xtra EC5 1 ltr	225943	Smurolía 0W/20 Quartz Ineo Xtra EC5 5 ltr	225944
Heiti							
Smurolía 0W/20 Quartz Ineo Xtra EC5 1 ltr	225943						
Smurolía 0W/20 Quartz Ineo Xtra EC5 5 ltr	225944						

KEY DATA

<p>LIGHT VEHICLE RANGE</p>  <p>PETROL & DIESEL ENGINE OIL SAE 0W-20 ADVANCED SYNTHETIC TECHNOLOGY LOW SAPS & XTRA FUEL ECONOMY</p> <div style="display: flex; justify-content: space-around;">    </div>	<p>INTERNATIONAL STANDARDS</p> <ul style="list-style-type: none"> • ACEA C5 • API SP (RC) • ILSAC GF-6A <p>MANUFACTURER APPROVALS¹</p> <ul style="list-style-type: none"> • MB-Approval 229.72 (backward compatible 229.71) • OPEL/VAUXHALL OV0401547 • FORD WSS-M2C947-B1 • FORD WSS-M2C962-A1 • JAGUAR LAND ROVER STJLR 03.5006 • VOLVO VCC RBS0-2AE • FIAT 9.55535-GSX (Meets the requirements of) • Chrysler MS-12145 (Meets the requirements of) <p><small>¹ Please refer to car owner's manual</small></p>
---	---

TOTAL Smurolía fyrir fólksbíla 0W/20

	Vörunúmer								
	<table border="1" style="width: 100%; border-collapse: collapse;"> <thead> <tr> <th style="width: 50%; text-align: left;">Heiti</th> <th style="width: 50%;"></th> </tr> </thead> <tbody> <tr> <td>Smurolía 0W/20 Quartz Ineo EC6 1 ltr</td> <td style="text-align: right;">228343</td> </tr> <tr> <td>Smurolía 0W/20 Quartz Ineo EC6 5 ltr</td> <td style="text-align: right;">228344</td> </tr> <tr> <td>Smurolía 0W/20 Quartz Ineo X EC6 208 ltr</td> <td style="text-align: right;">228338</td> </tr> </tbody> </table>	Heiti		Smurolía 0W/20 Quartz Ineo EC6 1 ltr	228343	Smurolía 0W/20 Quartz Ineo EC6 5 ltr	228344	Smurolía 0W/20 Quartz Ineo X EC6 208 ltr	228338
Heiti									
Smurolía 0W/20 Quartz Ineo EC6 1 ltr	228343								
Smurolía 0W/20 Quartz Ineo EC6 5 ltr	228344								
Smurolía 0W/20 Quartz Ineo X EC6 208 ltr	228338								

ACEA C6, C5 API SP (RC) ILSAC GF-6A

ASTON MARTIN Twin Turbo V12 engines (AE31, AE34) Service fill approved
 Ford WSS-M2C-947-B1, Ford WSS-M2C-962-A1, Jaguar Land Rover STJLR.03.5006
 MB-APPROVAL 229.72 (Retro-compatible 229.71) Opel/Vauxhall OV0401547 - A20
 Volvo VCC RBS0-2AE, Meets the requirement of Chrysler MS-12145
 Meets the requirement of : FIAT 9.55535-GSX, Backward compatible : MB-229.71



Smurólía fyrir fólksbíla

Bensín og Dísel



0W/20

Heiti	Vörunúmer
Smurólía 0W/20 Quartz Ineo Xtra 1 ltr V-Drive	226022
Smurólía 0W/20 Quartz Ineo Xtra 5 ltr V-Drive	226025

KEY DATA

LIGHT VEHICLE RANGE



GASOLINE AND DIESEL ENGINE OIL
SAE 0W-20
ADVANCED SYNTHETIC TECHNOLOGY
LOW SAPS & XTRA FUEL ECONOMY



INTERNATIONAL STANDARDS

- ACEA C5
- API SN/CF

MANUFACTURER APPROVALS¹

- VOLVO VCC RBS0-2AE

¹Please refer to car owner's manual



Smurólía fyrir fólksbíla

Bensín og dísel



0W/20

Heiti	Vörunúmer
Smurólía 0W20 Quatz Ineo Xtra 5 ltr Dynamics	226004

KEY DATA



LIGHT VEHICLE RANGE

GASOLINE AND DIESEL ENGINE OIL
SAE 0W-20
ADVANCED SYNTHETIC TECHNOLOGY
LOW SAPS & XTRA FUEL ECONOMY

INTERNATIONAL STANDARDS

- ACEA C5
- API SN-RC
- ILSAC GF-5

MANUFACTURER APPROVALS¹

- ASTON MARTIN Twin Turbo V12 engines: Service fill approved
- BMW LL-17 FE+ (backward compatible BMW LL-14FE+)
- Suitable for FORD WSS-M2C952-A1

¹Please refer to car owner's manual



Smurólía - Fólksbílar



0W/20 OLÍA

Full synthetic

Heiti

Vörunúmer

SYNPOWER XL-IV C5 0W/20 1 LTR

044 882800

SYNPOWER XL-IV C5 0W/20 5 LTR

044 882861

O.E.M. Approvals

Porsche C20

VW 50800/50900

Performance levels

ACEA C5

API: SN+, SN

VW TL 52577



Smurólía - Fólksbílar



0W/20 OLÍA

Full synthetic

Heiti

Vörunúmer

SYNPOWER FE 0W/20 1 LTR

044 872583

SYNPOWER FE 0W/20 5 LTR

044 872584

Approvals

Volvo VCC RBS0-2AE

Performance levels

ACEA C5



Smurólía - Fólksbílar



0W/20 C5

Full synthetic

Heiti

Vörunúmer

HYBRID C5 0W-20 1 LTR

044 892409

HYBRID C5 0W-20 5 LTR

044 892410

HYBRID C5 0W-20 208LTR

044 897022

Performance levels

ACEA: C5

API: SP

API: SN



Smurólía - Fólksbílar



0W/30 Olía

Heiti

Vörunúmer

Smurólía 0W-30 SynPower XL III C3 1 ltr	044 882243
Smurólía 0W-30 SynPower XL III C3 5 ltr	044 882242

Approvals & Specifications

BMW LL-04
MB-Approval 229.52
VW 504 00/507 00
ACEA C3
MB-229.51
MB-229.31
Porsche C30



Smurólía - Fólksbílar



0W/30 Olía

DT C2

Full synthetic

Heiti

Vörunúmer

SYNPOWER DT C2 0W/30 1 LTR	044 875423
SYNPOWER DT C2 0W/30 5 LTR	044 873950

Performance levels

ACEA C2
Fiat 9.55535 GS1
Ford WSS-M2C950-A
Jaguar/ Landrover STJLR 03.5007
Suitable for use in some models of: Honda, Jeep, Mitsubishi, Subaru, Suzuki, Toyota, * and where Fiat 9.55535.GS-1 is specified (Fiat petrol engines only).

* please consult owners manual before use



Smurólía - Fólksbílar



0W/30 Olía

Full synthetic

Heiti

Vörunúmer

SYNPOWER FE 0W/30 1 LTR	044 872560
SYNPOWER FE 0W/30 4 LTR	044 872564

Volvo & Amerískir

Approvals

Volvo 95200377
Performance levels
ACEA A5/B5
ACEA A1/B1
API: SL



Smurólía - Fólksbílar



0W/30 Olía

Heiti

Vörunúmer

Smurólía 0W/30 Evolution 900 FT 5 ltr	213992
▪ ACEA : A3/B4	VOLKSWAGEN : VW 502.00 / 505.00
▪ API : SL/CF	RENAULT : RN0700 / RN0710
	MERCEDES BENZ : MB-Approval 229.5



Smurólía - Fólksbílar

0W/30 Olía



Heiti

Vörunúmer

Smurólía 0W/30 Energy Quartz 9000
5 ltr

213686

ACEA A3 / B4-08
API SL / CF
MB 229.5
VW 502.00 / 505.00
VW 501.01, 500.00

TOTAL recommends use with:
BMW LL-01
OPEL / SAAB GM-LL-A-025
OPEL / SAAB GM-LL-B-025
FIAT 9.55535-M2
FIAT 9.55535-N2



Smurólía - Fólksbílar

0W/30 Olía



Heiti

Vörunúmer

SYNPOWER ENV C2 0W/30 1 LTR
SYNPOWER ENV C2 0W/30 5 LTR

Full synthetic
044 872518
044 872519

Approvals

PSA B71 2312 for service fill (MA6)

Performance levels

ACEA C2

Meets requirements of:

Citroën*

* model specific. Please consult owners manual before use



Smurólía - Fólksbílar

0W/30 Olía



Heiti

Vörunúmer

Smurólía 0W/30 Quartz Ineo First
1 ltr
Smurólía 0W/30 Quartz Ineo First
5 ltr
Smurólía 0W/30 Quartz Ineo First
208 ltr

213830
213833
181135

KEY DATA

LIGHT VEHICLE RANGE



GASOLINE & DIESEL ENGINE OIL
SAE 0W-30
ADVANCED SYNTHETIC TECHNOLOGY
LOW SAPS & FUEL ECONOMY



INTERNATIONAL STANDARDS

- ACEA C1

MANUFACTURER APPROVALS¹

- PSA B71 2312 & 2302
- Meets the requirements of JAGUAR LAND ROVER STJLR.03.5007
- Suitable for TOYOTA

¹Please refer to car owner's manual



Smurólía - Fólksbílar

0W/30 Olía



Heiti	Vörunúmer
Smurólía 0W/30 Quartz Ineo FDE 1 ltr	216186
Smurólía 0W/30 Quartz Ineo FDE 5 ltr	216187
Smurólía 0W/30 Quartz Ineo FDE 20 ltr	211160

KEY DATA

LIGHT VEHICLE RANGE



GASOLINE & DIESEL MOTOR OIL
SAE 0W-30
SYNTHETIC TECHNOLOGY
LOW SAPS

INTERNATIONAL STANDARDS

✓ ACEA C2

MANUFACTURER SPECIFICATIONS

✓ FORD: WSS-M2C950-A (Meets the requirements)



Smurólía - Fólksbílar

0W/30 Olía

Mazda



Heiti	Vörunúmer
Smurólía 0W/30 Mazda Original Supra 1 ltr Original Supra DPF	206490



Smurólía - Fólksbílar

0W/40 Olía

Bensín og dísel



Heiti	Vörunúmer
Smurólía 0W-40 Quartz 9000 Energy 5 ltr	213989

- ACEA A3/B4
- API SN/CF

- ASTON MARTIN: Approved for 4.0L TwinTurbo V8 & 6.0L V12 Naturally aspirated engines
- MB-Approval 229.5
- PORSCHE A40
- VW 502.00/505.00
- FORD WSS-M2C 937-A





Smurólía - Fólksbílar og fleira



Not recommended for Ford models:
 * Ka from Aug. 2008 onwards (petrol)
 * Focus ST (2004 -3th quarter) with 2.5 Duratec ST (VI5) engine. (petrol)
 * Focus RS (2004 -3th quarter) with Duratec RS (VI5) engine.(petrol)

5W/20 Olía Full synthetic

Heiti	Vörunúmer
SYNPOWER FE 5W-20 1 Ltr	044 872555
SYNPOWER FE 5W-20 5 Ltr	044 872556
SYNPOWER FE 5W-20 20 Ltr	044 872557

Approval
Jaguar Land Rover STJLR.03.5004
Performance levels
ACEA C5
ACEA A1/B1
API: SN Plus RC
ILSAC GF-5
In warranty service fill where Ford WSS-M2C948-A & B (petrol engines) are required.
Backwards compatible with Ford WSS-M2C913-B, C and WSS-M2C925-B.



Smurólía - Fólksbílar



5W/20 Olía

Heiti	Vörunúmer
Smurólía 5W-20 Quartz 9000 Ineo EcoB 1 ltr	213978
Smurólía 5W-20 Quartz 9000 Ineo EcoB 5 ltr	213979
Smurólía 5W-20 Quartz 9000 Ineo EcoB 208 ltr	213857

KEY DATA

LIGHT VEHICLE RANGE



PETROL ENGINE OIL
 SAE 5W-20
 SYNTHETIC TECHNOLOGY
 FUEL ECONOMY



INTERNATIONAL STANDARDS

- ACEA C5
- API SN

MANUFACTURER APPROVALS¹

- Ford WSS-M2C-948-B
- Jaguar Land Rover STJLR.03.5004

¹Please refer to car owner's manual



Smurólía - Fólksbílar



5W/20 Olía Full synthetic

Heiti	Vörunúmer
Smurólía 5W-20 Max 1 Advanced GF6 5 Ltr	F0094530

Specification	0W-16	0W-20 dexos®	5W-20
API SP	•	•	•
API SN Plus/SN*	✓	✓	✓
ILSAC GF-6A	-	•	•
ILSAC GF-6B	•	-	-
ILSAC GF-5*	-	✓	✓
Chrysler MS-6395	-	✓	-
Ford WSS-M2C960-A1	-	-	✓
Ford WSS-M2C961-A1	-	-	-
Ford WSS-M2C962-A1	-	✓	-
Ford WSS-M2C945-B1*	-	-	✓

Smurolía - Fólksbílar

5W/20 Ólífa



Motorcraft



Heiti

Vörunúmer

Synthetic blend

MOTORCRAFT 5W/20 4,732 ltr

102 MC5205QT

ILSAC GF-5

WSS-M2C945-A

FORD,LINCOLN OR MERCURY



Smurolía - Fólksbílar og fleira

5W/40

C3

Bensín og díselbílar

Heiti

Vörunúmer

Full synthetic

ALL-CLIMATE C3 5W/40 1 L

044 872278

ALL-CLIMATE C3 5W/40 5 L

044 872277

ALL-CLIMATE C3 5W/40 208 LTR

044 872274



Performance levels

ACEA C3

API: SM, SN/CF

BMW LL-04

MB-226.5, 229.31

Ford WSS-M2C917-A

GM Dexos 2

Porsche A40

Renault RN0700/0710

VW 50500 / 50501



Smurolía - Fólksbílar og fleira

5W/40

Heiti

Vörunúmer

Smurolía 5W-40 Quartz 9000
5 Ltr

213678

Smurolía 5W-40 Quartz 9000
208 ltr

110742



KEY DATA

LIGHT VEHICLE RANGE



GASOLINE & DIESEL ENGINE OIL
SAE 5W-40
ADVANCED SYNTHETIC TECHNOLOGY



INTERNATIONAL STANDARDS

- ACEA A3/B4
- API SN/CF

MANUFACTURER APPROVALS¹

- PSA B71 2296
- RENAULT RN 0700/0710
- MB-Approval 229.5
- VW 502.00/505.00
- PORSCHE A40
- Meets the requirements of CHRYSLER MS-12991
- Meets the requirements of FIAT 9.55535-M2

¹Please refer to car owner's manual



Smurólía - Fólksbílar og fleira

5W/40

Heiti

Vörunúmer



Smurólía 5W-40 Quartz Ineo C3 MC3
208 ltr

213101

KEY DATA

LIGHT VEHICLE RANGE



PETROL & DIESEL ENGINE OIL

SAE 5W-40

SYNTHETIC TECHNOLOGY

LOW SAPS

INTERNATIONAL STANDARDS

- ✓ ACEA C3
- ✓ API SN/CF

MANUFACTURER APPROVALS*

- ✓ MERCEDES-BENZ MB-Approval 229.51
- ✓ VOLKSWAGEN : VW 502.00 / 505.01
- ✓ PORSCHE A40
- ✓ GENERAL MOTORS
Official dexos2™ license : meets the latest technical requirements of GM engines (Opel, Vauxhall, Chevrolet)
- ✓ Meets the requirements of FORD WSS-M2C 917-A
- ✓ Meets the requirements of FIAT 9.55535-S2
- ✓ Meets the requirements of FIAT 9.55535-GH2



Smurólía - Fólksbílar og fleira

5W/40

Heiti

Vörunúmer



Smurólía 5W-40 Quartz Ineo C3
1 ltr

213789

Smurólía 5W-40 Quartz Ineo C3
5 ltr

213790

KEY DATA

LIGHT VEHICLE RANGE



GASOLINE & DIESEL ENGINE OIL
SAE 5W-40
ADVANCED SYNTHETIC TECHNOLOGY
LOW SAPS & FUEL ECONOMY



INTERNATIONAL STANDARDS

- ACEA C3
- API SN/CF

MANUFACTURER APPROVALS¹

- MB-Approval 229.51
- VW 505.00/505.01
- PORSCHE A40
- Meets the requirements of:
 - GM Dexos 2
 - FIAT 9.55535-S2
 - FORD WSS-M2C917-A

¹Please refer to car owner's manual



Smurólía - Fólksbílar og fleira
Bensín og Dísel bílar

15W/50

Heiti

Vörunúmer



Smurólía 15W-50 Evolution 700 ST
5 ltr

213882

PERFORMANCES

Spécifications internationales

ACEA : A3/B4
API : SN/CF

Homologations constructeurs

VOLKSWAGEN VW 501.01 / 505.00
MERCEDES BENZ MB-Approval 229.1



Smurólía - Fólkspílar

5W/50 Olía

RACING OLÍA

Heiti

Vörunúmer



RACING VR1 SAE 5W/50 4 Ltr

044 873434

Approvals & Specifications

ACEA A3/B4

API SL, SM

Ford WSS-M2C-153E

GM 6094M



Smurólía - Fólkspílar

20W/50 Olía

RACING OLÍA

Heiti

Vörunúmer



RACING VR1 SAE 20W/50 1 LTR

044 873431

RACING VR1 SAE 20W/50 5 LTR

044 873432

Approvals & Specifications

ACEA A3/B4

API SL, SM

Ford WSS-M2C-153E

GM 6094M



Smurólía - Fólkspílar

10W/60 Olía

RACING OLÍA

Heiti

Vörunúmer



RACING VR1 SAE 10W/60 1 LTR

044 873338

RACING VR1 SAE 10W/60 5 LTR

044 873339

Approvals & Specifications

ACEA A3/B4

API SL, SM

Ford WSS-M2C-153E

GM 6094M

Recommended for use where Fiat 9.55535.H3 is specified.



Smurólía - Fólkspílar- Fornbílar

20W/50 Olía

Heiti

Vörunúmer



SAE 20W/50

Fyrir fornbíla



CLASSIC OLÍA M/ ZDDP 20W/50
5 ltr

311 V37S 20W/50

Smurólía 20W-50 HTX Retro 2
5 ltr Fyrir bíla 1960-1980

209715





Smurólía - Vörubíla og vinnuvélar

5W/30

Full synthetic



Heiti

Vörunúmer

Full synthetic

PRO-FLEET LS 5W/30 20 LTR

044 797172

PRO-FLEET LS 5W/30 208 LTR

044 797004

O.E.M. Approvals

Deutz DQC IV-18 LA
MAN M3677, M3775
MB-Approval 228.51, 228.52
Mack EO-O Premium Plus
Renault RLD-3
Scania LDF-4
Volvo VDS-4

Performance levels

ACEA E4, E6, E7, E9
API: CK-4
Caterpillar ECF-3
Cummins CES 20081, CES 20086
DAF*
Detroit DFS 93K218, K222
Iveco 18-1804 TLS E6
MAN M 3271, M3477
MB-228.31
MTU Type 3.1, 2.1
Volvo VDS-3

* Check owner's manual before use



Smurólía - Vörubíla og vinnuvélar

5W/40

Vörunúmer



Heiti

PREMIUM BLUE EXTREME 5W/40 20L

044 703679

O.E.M. Approvals

Cummins CES 20081

Performance levels

API: CI-4, CI-4 plus, CJ-4/ SM, SN
Caterpillar ECF-3
Chrysler MS 10902
Detroit Diesel 93K218/ 93K215
Global DH-1
JASO DH-2
MAN M 3575
MB-228.3, 228.31
Volvo VDS-4
Mack EO-O Premium Plus
Renault RVI RLD-3





Smurólía - Vörubíla og vinnuvélar

10W/30

Semi-synthetic

Heiti

Vörunúmer



ALL-FLEET SUPERIOR LE 10W/30
20 LTR

044 886581

ALL-FLEET SUPERIOR LE 10W/30
208 LTR

044 886586



Performance levels

ACEA: E7, E9
API: CK-4, CI-4, CI-4+, CH-4, CJ-4
Caterpillar ECF-3
Cummins CES 20086, CES 20081
Detroit Diesel DFS 93K222, 93K218
Detroit Diesel PGOS (93K218)
Deutz DQC III-10 LA, II-10 LA
Ford WSS-M2C171-F1
JASO DH-1, DH-2
Mack EO-N Premium Plus
MAN 3575
Renault RLD-4
Volvo VDS-4, VDS-3

O.E.M. Approvals

MB-Approval 228.31
Mack EOS-4.5
MTU Type 2.1
Renault RLD-3
Volvo VDS-4.5 (417-003-18-429)



Smurólía - Vörubíla og vinnuvélar

10W/30

Heiti

Vörunúmer



Smurólía 10W-30 Rubia Optima 1100 FE
20 Ltr

207848



SPECIFICATIONS AND APPROVALS

International specifications

Meets the requirements of **API CK-4/CJ-4/CI-4 plus/CI-4/CH-4** **ACEA E9/E7**

Manufacturers' approvals

- ✓ Mack EO-S 4.5
- ✓ Volvo VDS-4.5
- ✓ Renault Trucks RLD-4
- ✓ Cummins CES 20086
- ✓ *Detroit Diesel DFS 93K222
- ✓ *Ford WSS-M2C171-F1

APPLICATIONS



Smurólía - Vörubíla og vinnuvélar

10W/30



Heiti

Vörunúmer

Smurólía 10W-30 Rubia TIR 7900 FE
20 ltr

161407

Smurólía 10W-30 Rubia TIR 7900 FE
208 ltr

161408



KEY DATA



SPECIFICATIONS AND APPROVALS

International Specifications:

ACEA E7-04, E9
API CJ-4/CI-4 plus/CI-4/CH-4/SM

Meets the Requirements of:

- ✓ DAF
- ✓ IVECO

Manufacturers' Approvals:

- ✓ Cummins CES 20081
- ✓ Detroit Diesel DDC Power Guard 93K218
- ✓ Mack EO-O Premium Plus
- ✓ MAN M 3575
- ✓ MB-Approval 228.31
- ✓ Renault Trucks RLD-3
- ✓ Volvo VDS-4



Smurólía - Vörubíla og vinnuvélar

10W/30



Heiti

Vörunúmer

Smurólía 10W-30 Rubia TIR 8900 FE
208 Ltr

159212



KEY DATA



SPECIFICATIONS AND APPROVALS

International Specifications:

ACEA E6, E7, E9
API CJ-4/CI-4/CH-4

Meets the Requirements of:

- ✓ Cummins CES 20081
- ✓ MAN M 3477/M 3271-1
- ✓ DAF
- ✓ IVECO

Manufacturers' Approvals:

- ✓ Mack EO-O Premium Plus
- ✓ MB-Approval 228.51
- ✓ Renault Trucks RLD-3
- ✓ Volvo VDS-4



Smurólía - Vörubíla og vinnuvélar

10W/40

Semi synthetic

Heiti

Vörunúmer



PRO-FLEET LS-X 10W/40 20 LTR

044 881885



PRO-FLEET LS-X 10W/40 208 LTR

044 881883



O.E.M. Approvals

Mack EO-O Premium Plus

MB-Approval 228.51

Renault RLD-3, RLD-2

Scania Low Ash

Volvo VDS-4 (417-0001-19-1018)

Performance levels

ACEA E6, E7, E9

API: CI-4, CJ-4

Caterpillar ECF-3, ECF-2

Cummins CES 20081

DAF*

DDC 93K218

Deutz DQC IV-10 LA

MAN M 3271-1/ M 3477

MB-228.31

MTU Type 3.1 & 2.1

Volvo VDS-3, CNG

* Check owner's manual before use



Smurólía - Vörubíla og Langferðabílar

10W/40

Synthetic blend

Heiti

Vörunúmer



Smurólía 10W-40 ProFleet LS Plus
208 ltr

044 901646



Applications

Suitable for all heavy-duty high performance Euro diesel engines in trucks and buses as well as industrial vehicles, with Exhaust Gas Recirculation (EGR), Selective Catalytic Reduction (SCR) systems and Diesel Particulate Filters (DPF). Fulfills the Ultra High-Performance Diesel (UHPD) recommendations of major engine builders.

Approvals & Specifications

ACEA E8, E7, E11

API CK-4, CJ-4, CI-4 PLUS, CI-4, CH-4/SN

Caterpillar ECF-3, ECF-2

Cummins CES 20086, CES 20081

Daimler Truck DTFR 15C120 (MB 228.52)

Daimler Truck DTFR 15C110 (MB 228.51)

Daimler Truck DTFR 15C100 (MB 228.31)

Detroit Diesel DDC 93K222

Deutz DQC IV-18 LA

JASO DH-2, DH-1

Mack EOS-4.5

MAN M3775

MTU type 3.1, type 2.1

Renault RLD-3

Voith Class B

Volvo VDS-4.5, VDS-4, VDS-3

*Check owner's manual before use



Smurólía - Vörubíla og Langferðabílar

10W/40

TIR 8600

Dísel vélar með túrbínu og án

Heiti

Vörunúmer



Smurólía 10W/40 Rubia TIR 8600
20 ltr

110801

ACEA E7, E4

API CF

APPROVED BY:

MB-Approval 228.5

MACK EO-N

MAN M 3277

Renault Trucks RXD, RLD-2

SCANIA LDF-3

VOITH Oil Class A

Volvo VDS-3

MEET THE REQUIREMENTS:

DAF

IVECO



Smurólía - Vörubíla og Langferðabílar

10W/40

TIR 8900

Heiti

Vörunúmer



Smurólía 10W/40 Rubia TIR 8900
5 Ltr

213694

KEY DATA



SPECIFICATIONS AND APPROVALS

International Specifications:

ACEA E6, E7, E9

API CJ-4/CI-4/CH-4

Manufacturers' Approvals:

- ✓ Mack EO-O Premium Plus
- ✓ MB-Approval 228.51
- ✓ Renault Trucks RLD-3
- ✓ Volvo VDS-4
- ✓ Scania Low Ash

Meets the Requirements of:

- ✓ MAN M 3477/M 3271-1
- ✓ DAF
- ✓ IVECO TLS E9
- ✓ Cummins CES 20081



Smurólía - Vörubíla og Langferðabílar

10W/40

Heiti

Vörunúmer



Smurólía 10W/40 rubia Optima 3100
5 ltr

228919

Smurólía 10W/40 rubia Optima 3100
20 ltr

228901

Smurólía 10W/40 rubia Optima 3100
208 ltr

228900



KEY DATA



Synthetic technology low-SAPS lubricant, suitable for use in heavy-duty on road diesel and gas engines.

INTERNATIONAL STANDARDS

- ACEA E6, E7, E8, E9, E11
- API CK-4/CJ-4/CI-4 plus/CI-4/CH-4

MANUFACTURER APPROVALS

- MB-Approval 228.51
- MB-Approval 228.52
- Mack EO-S 4.5
- Volvo VDS-4.5
- Renault Trucks RLD-3
- Cummins CES 20086

MEETS THE REQUIREMENTS OF

- MAN M 3477/M 3271-1
- DAF

SUITABLE FOR

- FPT IVECO CATEGORY TLS E9
- FPT IVECO CATEGORY TLS CK-4



Smurólía - Vörubíla og vinnuvélar

10W/40

Works 4000

Heiti

Vörunúmer



Smurólía 10W/40 Rubia Works 4000 20 ltr	211428
Smurólía 10W/40 Rubia Works 4000 208 ltr	211427

SPECIFICATIONS AND APPROVALS

International specifications	ACEA E9/E7	API CK-4/CJ-4/CI-4+/CI-4/CH-4/SN	JASO DH-2
------------------------------	------------	----------------------------------	-----------

Manufacturers' approvals

- ✓ DEUTZ DQC III-10 LA
- ✓ MTU Category 2.1
- ✓ MB-Approval 228.31
- ✓ VOLVO VDS-4.5
- ✓ MACK EO-S 4.5
- ✓ RENAULT VI RLD-3
- ✓ CUMMINS CES 20086
- ✓ DETROIT DIESEL DFS 93K222
- ✓ MAN M3775
- ✓ ISUZU Recommended Lubricant (2020)

Meets the requirements of

- ✓ CATERPILLAR ECF-3/ECF-2/ECF-1a
- ✓ IVECO FPT TLS E9

Especially recommended in engines of machinery

- ✓ KOMATSU
- ✓ HITACHI
- ✓ JCB
- ✓ KOBELCO
- ✓ etc...

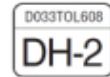

PRODUCT MEETING JASO M 355
COMPANY GUARANTEEING THIS PERFORMANCE:
TOTAL LUBRICANTS



Smurólía - Vörubíla og vinnuvélar

15W/40

Semi-synthetic

Heiti

Vörunúmer



ALL-FLEET SUPERIOR 15W/40 LE 5 LTR	044 889599
ALL-FLEET SUPERIOR 15W/40 LE 20 LTR	044 886248
ALL-FLEET SUPERIOR 15W/40 LE 208 LTR	044 886247

Performance levels

ACEA: E7, E9
API: CK-4, CI-4, CI-4+, CH-4, CJ-4
Caterpillar ECF-3
CES 20086, CES 20081
Detroit Diesel DFS93 K222, K218
Ford WSS-M2C171-F1
Deutz DQC III-10 LA, II-10 LA
JASO DH-1, DH-2
Mack OE-N Premium Plus, OE-S-4.5
MAN 3575
MAT 3521, MAT 3522
Renault RLD-3
Volvo VDS-4, VDS-3

O.E.M. Approvals

MB-Approval 228.31
MTU Type 2.1
Renault RLD-4
Volvo VDS-4.5



Smurolía - Vörubíla og vinnuvélar

15W/40



Heiti	Vörunúmer
Smurolía 15W-40 Rubia TIR 7400 5 ltr	213669
Smurolía 15W-40 Rubia TIR 7400 20 ltr	113430
Smurolía 15W-40 Rubia TIR 7400 208 ltr	113452

KEY DATA



SPECIFICATIONS AND APPROVALS

International Specifications:

- ACEA E7
- API CI-4/CH-4/SL

Manufacturers' Approvals:

- ✓ Cummins CES 20078
- ✓ Mack EO-N
- ✓ MB-Approval 228.3
- ✓ Renault Trucks RLD-2
- ✓ Volvo VDS-3
- ✓ Isuzu Recommended Lubricant (2020)*

*For transfer case only

Meets the Requirements of:

- ✓ CATERPILLAR ECF-1-a
- ✓ IVECO T2 E7
- ✓ MAN M 3275
- ✓ DAF
- ✓ SCANIA



Smurolía - Vörubíla og vinnuvélar

15W/40



Heiti	Vörunúmer
Smurolía 15W-40 IDO Premium Plus CK-4 5 ltr	F0114130
Smurolía 15W-40 IDO Premium Plus CK-4 18,9 ltr	F0080540
Smurolía 15W-40 IDO Premium Plus CK-4 205 ltr	F0075050

Specifications

Meets Requirements Of:	15W-40 CK-4
API CK-4, CJ-4, CI-4 PLUS, CI-4, CH-4	✓
CAT ECF-3	✓
FORD WSS-M2C171-F1	✓
Cummins CES 20086	✓
Detroit Diesel DDC93K222	✓
MACK EOS-4.5	✓
VOLVO VDS 4.5	✓
Renault VI RLD-4	✓
ACEA E7-16, E9-16	✓
MB 228.31	✓
MAN 3575	✓
MAN 3275	✓
MTU Category 2.1	✓
Deutz DQC III-10 LA	✓
JASO DH-2 MRO (Meets requirements of)	✓



Smurólía - Vörubíla, báta og vinnuvélar

15W/40



Heiti

Vörunúmer

ALL-FLEET EXTRA 15W/40 5 LTR

044 13711

ALL-FLEET EXTRA 15W/40 20 LTR

044 13706

ALL-FLEET EXTRA 15W/40 208 LTR

044 13718

O.E.M. Approvals

Deutz DQC III-10

MB-Approval 228.3

MTU Type 2

Volvo VDS-3 (417-0002-1629)

Renault RLD/RLD-2

Mack EO-N, EO-M Plus

Performance levels

ACEA E7

API: CI-4, CH-4

Caterpillar ECF-2, ECF-1-a

Cummins CES 20077/78

DDC 93K215

Global DHD-1

MAN M 3275-1



Smurólía - Vörubíla og vinnuvélar

15W/40



Heiti

Vörunúmer

PREMIUM BLUE 15W/40 5 LTR

044 870236

PREMIUM BLUE 15W/40 20 LTR

044 870235

Performance levels

ACEA E7

API: CI-4/ SL

Caterpillar ECF-2

Cummins CES 20076, CES 20077

Detroit Diesel DFS 93K215

Deutz DQC III-18

Global DHD-1

MAN M3275

MB-228.3

O.E.M. Approvals

Cummins CES 20078

MTU Type 2

Volvo VDS-3

Mack EO-N

Renault VI RLD-2



Smurolía - Vörubíla, báta og vinnuvélar

15W/40

Fyrir dísel vélar.

Heiti

Vörunúmer



Smurolía 15W-40 Rubia Optima 1100
20 ltr

207892

Smurolía 15W-40 Rubia Optima 1100
208 ltr

207893



KEY DATA



SPECIFICATIONS AND APPROVALS

International Specifications:

ACEA E7, E9

API CK-4/CJ-4/CI-4 plus/CI-4/CH-4/SN

Meets the Requirements of:

- ✓ DAF
- ✓ IVECO

Manufacturers' Approvals:

- ✓ MB-Approval 228.31
- ✓ Mack EO-S 4.5
- ✓ Volvo VDS-4.5
- ✓ Renault Trucks RLD-3
- ✓ Cummins CES 20086
- ✓ Detroit Diesel DFS 93K222
- ✓ Ford WSS-M2C171-F1



Smurolía fyrir flugvélar

15W/50

Heiti

Vörunúmer



Smurolía 15W-50 Aero DM
1 ltr Fyrir flugvélar

213750



SPECIFICATIONS

AERO DM 15W-50 meets the following specifications and technical instructions:

- SAE J-1899
- LYCOMING SI 1014M, SI 1409C, SB 446E, SB 471B
- CONTINENTAL MOTORS SIL16-2, M-0
- FAA AD 08-04-03.
- French Air Force approved (n° 30330 STPA/MA).



Smurólía - Dráttarvélar
Mótorólía og Gírolía
 Fyrir blautbrensur og fleira.



10W/30 S.T.O.U

Heiti **Vörunúmer**

S.T.O.U. 10W/30 20 LTR 044 17006 044 890745
 S.T.O.U. 10W/30 208 LTR 044 890744

Performance levels
ISO L-E/C/H
API: CF-4, CE/SF
API: GL-4
Allison C3, C4
Caterpillar TO-2
Ford M2C 159B, C
Ford M2C 86B, C, 134 D,
Ford NH 82009201, 2, 3
J.I Case/Case Int: MS-1204, 6, 7, 9
CNH MAT 3525, 3526
John Deere JDM J27, J20C, J20D
MF M1139, M1144, M1145
ZF TE-ML 06A, B, C, R, 07B



Smurólía - Dráttarvélar
Mótorólía og Gírolía
 Fyrir blautbrensur og fleira.

10W/30 S.T.O.U

Heiti **Vörunúmer**



Smurólía 10W-30 Multagri Super 110659
 20 Ltr
 Smurólía 10W-30 Multagri Super 111811
 208 Ltr

KEY DATA



- ✓ AGRICULTURE
- ✓ STOU

SPECIFICATIONS AND APPROVALS

International Specifications:

ACEA E2
 Engines: API CF-4/CE/SF
 Transmissions: API GL-4

Manufacturers' Approvals:

- ✓ Massey Ferguson CMS M 1145
- ✓ ZF TE-ML 06B/07B

Meets the requirements:

- ✓ Engines: Ford M2C 159B1, Massey Ferguson CMS M1139/M1144, John Deere JDM J27
- ✓ Transmissions: John Deere JDM J20A/J20C, Ford M2C 86A/M2C 134D/FNHA 2C 201.00, Massey Ferguson CMS M1127A/M1135/M1143
- ✓ Automatic Transmissions: Caterpillar TO-2, Allison C4



Heiti **Vörunúmer**

Mælikönnur sett 5 stk 5ltr 066 JDL5SET

Mælikanna með loki 5 ltr 066 JDL5



Smurólía - Dráttarvélar
Mótorólía og Gírolía
Fyrir blautbrensur og fleira.



Suitable for use in:**

AGCO CVT
 Claas CVT
 Fendt Vario

10W/40

S.T.O.U

Heiti

Vörunúmer

S.T.O.U. 10W/40 20 LTR

044 881223

S.T.O.U. 10W/40 208 LTR

044 881222

Performance levels

API: CF-4/SF
API: GL-4
Allison C4
Ford M2C134 A, 159 B, 159 C
FNH 82009203
John Deere J27
MF M1144, M1145
ZF TE-ML 05K, 06B, 06C, 07B, 07D



Smurólía - Dráttarvélar -Vinnuvélar
Mótorólía og Gírolía
Fyrir blautbrensur og fleira.



10W/40

S.T.O.U

Heiti

Vörunúmer

Smurólía 10W/40 Multagri Pro-tec
 20 ltr

147626

Smurólía 10W/40 Multagri Pro-tec
 208 ltr

147627

KEY DATA



✓ AGRICULTURE
 ✓ STOU

SPECIFICATIONS AND APPROVALS

International Specifications:

ACEA E3
 Engines: API CG-4/SF
 Transmissions: API GL-4

Manufacturers' Approvals:

✓ Massey Ferguson CMS M 1145
 ✓ ZF TE-ML 06B/07B

Meets the requirements of:

✓ Engines: Ford M2C 159B3, Massey Ferguson CMS M1139/M1144, John Deere JDM J27
 ✓ Transmissions: Case MS 1206/1207, John Deere JDM J20A/J20C, Ford M2C 86A/M2C 134C/M2C 134D/FNHA 2C 201.00, Massey Ferguson CMS M1127A/M1135/M1143
 ✓ Automatic Transmissions: Caterpillar TO-2, Allison C4



Handþvottakrem frá Tub o' Scrub



Heiti

Vörunúmer

Handþvottakrem Tub O Scrub 18oz

102 TS18

Inniheldur Valhnetu skel
 Fjarlægir olíu, feiti og þykkan skít án vatns.

Inniheldur lanólín, Aloe og Vítamín E
 Niðurbjótanlega formúla sem stíflast ekki í niðurföllum.



Smurólía - Dráttarvélar
Mótorólía og Gírolía
Fyrir blautbrensar og fleira.



Suitable for use in**:

AGCO CVT
 Claas CVT
 Fendt Vario

**Check owner's manual before use.

15W/40

S.T.O.U

Heiti

Vörunúmer

S.T.O.U 15W/40 20 LTR

044 17046

S.T.O.U 15W/40 205 LTR

044 17058

Performance levels

API: CF-4, CE/SF

API: GL-4

Allison C3, C4

Caterpillar TO-2

Ford M2C-159-B, 30, 40 series

John Deere JDM J27

MF M1139, M1144, MF1145

ZF TE-ML-06A,B,C,D, 07B



Smurólía - Dráttarvélar
Mótorólía og Gírolía
Fyrir blautbrensar og fleira.



15W/40

EEE S.T.O.U

Heiti

Vörunúmer

S.T.O.U 15W/40 EEE 20 LTR

044 890743

S.T.O.U 15W/40 EEE 208 LTR

044 890742

Performance levels

ISO L-E/C/H

API: CF-4, CE/SF

API: GL-4

Allison C3, C4

Caterpillar TO-2

Ford M2C 159B, C

Ford M2C 86B, C, 134 D,

Ford NH 82009201, 2, 3

J.I Case/Case Int MS-1204, 6, 7, 9

CNH MAT 3525, 3526

John Deere JDM J27, J20C, J20D

MF M1139, M1144, M1145

ZF TE-ML 06A, B, C, R, 07B

ADBLUE fyrir Fólksbíla og fleira.



Heiti

Vörunúmer

ADBLUE 4,7 lítra

106.05

ADBLUE 10 lítra brúsi með barka/stút

106.1

ADBLUE 200 lítra plasttunna

105.3

ADBLUE 1000 lítra kar

104

MÆLIR FYRIR AdBlue

066 AK4125



Heiti

Vörunúmer

Tunnudæla 12V/230V fyrir Adblue

066 TP6818

Adblue dæla, 12V fyrir tunnur og kör

42912



Dráttarvélar - Gírolía-Glussi fyrir blautbremsur 40W

Má ekki fara á mótörinn.

Heiti

Vörunúmer



Glussi Tractor Hydraulic fjölnota olía
3,78 ltr

F0020426

Glussi Tractor Hydraulic fjölnota olía
18,9 ltr

F0086140



Specifications

Meets requirements of:	Meets requirements of:
AGCO 821XL	John Deere J20A
Allison C2, C3	John Deere J20B
Allison C4	John Deere J20C
API GL-4	John Deere J20D
Caterpillar TO-2	John Deere J14A-C
CNH MAT 3505	John Deere JTD 303
CNH MAT 3510	John Deere J21A
CNH MAT 3525	Kiotei
CNH MAT 3526	Komatsu KES 07.866, AXO80
Dennison HF-0, HF-1, HF-2 (except demulsibility)	Komatsu-Dresser B06.0002
Deutz-Allis Power Fluid 821XL, 25741, 25743, 246634, 272843	Kubota UDT
Dresser	Landini
Fiat Heston AF-87	MF M1110
Ford ESN-M2C-86 A-C	MF 1127, 1127 A&B
Ford FNHA-2-C-200	MF M1129, M1129A (Permatran)
Ford FNHA-2-C-201	MF M1135 (Permatran III)
Ford M2CA-C	MF M1138
Ford ESN-M2C134A-D (NH-401B)	MF M1139 (STOU) (UTTO Only)
Ford ESN-M2C-77A	MF M1141
Ford ESN-M2C86A, B, & C	MF M1143
Ford ESN-M2C-41, 41A & B, & 43	MF M1144 (STOU) (UTTO Only)
Ford ESN-M2C-48 B & C	MF M1145
Ford ESN-M2C53 A & B	Parker (Denison UTTO) HF-0, HF-1, HF-2
Ford ESN-M2C-142A	Quatrol
Ford ESN-M2C-143	Renk-Doromat 87.3 & 874A/B
Ford ESN-M2C-92A	Sauer Sunstrand/Danfoss & Hydro Static Trans Fluid
Ford ESN-M2C-159 A-C	Sperry Vickers/Eaton I-286S Industrial Hydraulics
Industry of Machinery and Tractors (IMT)	Sperry Vickers/Eaton M2950S Mobil Hydraulics
International Harvester Hy-Tran B-6	Steiger HTF (SEMS 17001)
Japanese Construction Mechanization Association (JCMAS), HK P-041 & P-042	Valmet
JI Case MS-143, 144, 145 International Farmall (TCH Fluid)	Valtractores
JI Case MS-185 (TFD Fluid)	Versatile Gear & Hydr Trans Fluid
JI Case MS1204-1205 (Powergard PFT)	Vickers 35VQ25
JI Case MS1206 (Powergard PFT)	Volvo WB101 (VCE97303), except for motor grader rear axle
JI Case MS1207	Volvo VCE 1273.03
JI Case MS1209 (HyTran Ultra or MultiTran)	Wet brake applications
JI Case MS1210	White/Minneapolis-Moline/Oliver/ New Idea 55, 5J, Q-1705, Q-1722, Q-1766, Q- 1766B, Q-1802, Q-1826
JI Case MS-1216	Yanmar
JI Case MS-1230 (Poclairn Equipment)	23M & 24M
JI Case MS-1317	

Irving Premium Tractor Hydraulic Fluid is a year-round, multi-grade product formulated for use in transmissions, final-drives, wet brakes and any farm tractors or construction equipment that uses a common fluid reservoir.

Irving Premium Tractor Hydraulic Fluid's characteristics are unique. One fluid lubricates the transmission, final drive, actuate hydraulic type disc brakes and services operation to power steering units, power take-offs, implements and attachments.

Typical Results

Test Method	THF All Season	THF 3 Season
COLOUR (D1500)	2.0	2.0
DENSITY @ 15°C (D4052), kg/L	0.87	0.86
VISCOSITY (D445) cSt @ 40 °C	40	59.9
cSt @ 100 °C	9.5	9.8
VISCOSITY INDEX (D2270)	233	149
POUR POINT (D97), °C	-42	-36
FLASH POINT (D93), °C	184	212
TOTAL BASE NUMBER (D2896), mgKOH/g	7.0	9.4
USEFUL OPERATING TEMP, °C, MIN/MAX	-17/82	-10/85



Dráttarvélar - Gírolía-Glussi fyrir blautbremsur

41W - 93W



Heiti

Vörunúmer

Dynatrans ACX 10W TO-4

207424

20 ltr

Dynatrans ACX 10W TO-4

207423

208 ltr

Dynatrans ACX 30 TO-4

207445

20 ltr

Lubricant for **hydraulic systems and transmission components** (axles or gearboxes) equipped with specific **brake friction discs**

SPECIFICATIONS AND APPROVALS

	DYNATRANS ACX 10W	DYNATRANS ACX 30	DYNATRANS ACX 50
Manufacturer Approvals	ZF TE ML 03C	ZF TE ML 03C ZF TE ML 07F	
Meets the requirements of	API GL-4 / CF CATERPILLAR TO-4 CATERPILLAR HYDO Advanced 10 ALLISON TES 439 ALLISON C4 (Obsolete) KOMATSU Micro Clutch test (JCMAS)	API GL-4 / CF CATERPILLAR TO-4 CATERPILLAR HYDO Advanced 30 ALLISON TES 439 ALLISON C4 (Obsolete) KOMATSU Micro Clutch test (JCMAS)	API GL-4 / CF CATERPILLAR TO-4 KOMATSU Micro Clutch test (JCMAS)
Suitable in Transmissions	DANA, EATON-FULLER, ROCKWELL, JCB, etc...	DANA, EATON-FULLER, ROCKWELL, JCB, etc...	DANA, EATON-FULLER, ROCKWELL, JCB, etc...

APPLICATIONS

TOTAL DYNATRANS ACX 10W, 30 & 50 are adapted to **hydraulic systems, Powershift gearboxes, axles and final drives** when the manufacturer recommends a fluid meeting CAT TO-4 or one of the above-mentioned specifications.

TOTAL DYNATRANS ACX is recommended for Mining, Earthmoving and Construction machinery applications.

- SAE 10W grade is mainly used in hydraulic systems
- SAE 30 grade is mainly used in Powershift gearboxes
- SAE 50 grade is mainly used in axles and final drives

TOTAL DYNATRANS ACX 10W and 30 should be used in replacement of **CATERPILLAR HYDO Advanced 10, 20 and 30**, with a drain interval extension up to 3000 working hours and more, within regular oil analysis.

PERFORMANCES AND CUSTOMER BENEFITS

- Excellent anti-wear and anticorrosion properties, increasing the durability of the lubricated organs
- Good performance with respect to seals, without aggressiveness to the pipes
- The 10W grade has a very fast air-release time and a good filterability, avoiding any cavitation risks in hydraulic pumps
- Friction properties suitable to the types of CATERPILLAR, KOMATSU and other Construction & Mining machinery
- Very shear stable viscosities preserving the hydraulic pumps volumetric efficiency
- Very fluid at low temperatures, they are immediately active when starting by cold climate
- Formulated with selected base oils associated to a recently developed chemistry, they provide to the end user, a better oxidation resistance at high temperature together with a draining interval extension
- Emulsifying, they fully keep condensation water in emulsion and avoid any pump breaks in Winter or rapid degradation in Summer

PHYSICAL AND CHEMICAL CHARACTERISTICS*

TOTAL DYNATRANS ACX	Method	10W	30	50	
Kinematic Viscosity at 40°C	mm ² /s	ASTM D445	41	93	195
Kinematic Viscosity at 100°C	mm ² /s	ASTM D445	6.6	11.2	18.4
Viscosity Index	-	ASTM D2270	118	107	104
Pour Point	°C	ASTM D97	-36	-30	-21
Zinc content (min)	ppm	ICP	900	900	900
Oxidation stability	h	ASTM D943	> 5000	> 5000	



Dráttarvélar - Gírolía fyrir blautbrensur

64W

Má ekki fara á mótörinn.

Heiti

Vörunúmer



Dynatrans MPV GL-4
20 ltr
Dynatrans MPV GL-4
208 ltr

154242
154240



Lubricant for **transmissions with oil immersed brakes and hydraulic systems used in agricultural tractors and Public Works or handling equipment.**

SPECIFICATIONS AND APPROVALS

International specifications **API GL-4**

Manufacturer's approvals

- ✓ MASSEY F. CMS M1145/M1143
- ✓ VALTRA G2-08
- ✓ VOLVO CE WB101
- ✓ ZF TE ML 03E/ 03L/ 05F/ 06P/ 17E/ 21F

Meets the requirements of the specifications :

- ✓ JOHN DEERE JDM J20C
- ✓ FORD M2C 134D / FNHA 2C 201.00
- ✓ Mc CORMICK HTX
- ✓ CLAAS / RENAULT AGRICULTURE

Suitable when the following specifications/products are recommended :

- ✓ MASSEY F. CMS M1141/M1135
- ✓ CASE MS 1206 / 1207 / 1209
- ✓ NEW HOLLAND NH 410B / NH 410C
- ✓ CNH MAT 3505 / 3509 / 3525 / 3526 / 3540
- ✓ KUBOTA UDT
- ✓ KOMATSU AXO 80
- ✓ AGCO/ Allis 821 XL

APPLICATIONS

TOTAL DYNATRANS MPV has been especially developed for **transmissions with wet brakes** requiring an API GL-4 lubricant with a 10W-30 or 80W viscosity grade, in both Off-Road and On-Road vehicles.

This lubricant is also perfectly adapted to **automatic transmissions, torque converters and hydrostatic transmissions** and more generally to any transmissions requiring an **UTTO** (Universal Tractor Transmissions Oil) lubricant.

TOTAL DYNATRANS MPV is also designed to lubricate **hydraulic systems, power-assisted steering and power-take-offs (PTO) with wet clutches.**

PERFORMANCES AND CUSTOMER BENEFITS

TOTAL DYNATRANS MPV is adapted to a wide range of agricultural and Public Works equipment and helps to reduce the stock and the number of lubricants.

This lubricants shows **excellent low temperature performances** (protects friction brakes against sticking) and **high temperature performances** (protects against judder or excessive slip).

TOTAL DYNATRANS MPV has very good **extreme pressure and anti-wear properties** giving optimum protection of gears and hydraulic components.

PHYSICAL AND CHEMICAL CHARACTERISTICS*

TOTAL DYNATRANS MPV		Method	Value
Kinematic Viscosity at 40°C	mm ² /s	ASTM D445	64
Kinematic Viscosity at 100°C	mm ² /s	ASTM D445	10.4
Viscosity Index	-	ASTM D2270	150
Pour Point	°C	ASTM D97	-39



Dráttarvélar - Gírolía fyrir blautbrensur 80W

Má ekki fara á mótörinn.



Heiti	Vörunúmer
UNITRAC 80W 5 LTR	044 882126
UNITRAC 80W 20 LTR	044 17106
UNITRAC 80W 208 LTR	044 17118

O.E.M. Approvals

ZF TE-ML 03E, 05F, 06D, 06K, 06N, 06R, 17E, 21F (ZF002041)

Performance levels:

API GL-4
Allison C3, C4
Case MAT 3505
CNH MAT 3540*
Ford M2C-134 A/B/C/D, M2C-86B/C
Ford/New Holland FNHA-2-C-200.00 (hydraulic oil 134)
Ford/NewHolland FNHA-2-C-201.00 (M2C-134D).
John Deere J20 A/B/C, J14B/C, J21A
Komatsu
Kubota UDT
Massey Ferguson M-1135, M-1141, M-1143, M-1145
Steiger SEMS 17001
Versatile 23M, 24M
Volvo 97303 (WB101)
White Farm (AGCO) Q-186

Unitrac

SAE Viscosity Grade	80W (10W-30)
Viscosity, mm ² /s @ 100 °C. ASTM D-445	10,0
Viscosity, mm ² /s @ 40 °C. ASTM D-445	63
Viscosity Index ASTM D-2270	143
TBN, mg KOH/g ASTM D-2896	9,0
TAN, mg KOH/g ASTM D-664	2,0
Pour Point, °C ASTM D-5949	-42
Specific Gravity @ 15.6°C. ASTM D-4052	0,876
Flash Point, COC, °C. ASTM D-92	220

Gírolía - Fólksbílar og fleiri.

75W



Heiti	Vörunúmer
-------	-----------

GÍROLÍA 75W 1 LTR	044 886573
-------------------	------------

GÍROLÍA 75W 20 LTR	044 886572
--------------------	------------

Performance levels

API: GL-4, GL-4 synthetic, GL-3, GL3 synthetic

BMW MTF LT-3

Ford WSS-M2C 186-A

Ford WSS-M2C 200-D2

GM 1940004/ 19259104 (BOT 303)

GM 1940764

VW G 052 171, G 052 178

VW G 052 512, G 052 527 A2

VW G 052 726, G 055 726

VW G 060 726, VW G 070 726 A2



Gírolía - Fólksbílar og fleiri.

75W

GL-4



Heiti	Vörunúmer
-------	-----------

Gírolía 75W Tranself NFX EKF C 1 ltr	223519
---	--------

Gírolía 75W Tranself NFX SAE 5 ltr	223530
---------------------------------------	--------

Gírolía 75W Tranself NFX EKF C 20 ltr	223503
--	--------

APPROVALS

Specifications

API GL-4

Manufacturers' approval

Officially approved and recommended by Renault-Nissan-Mitsubishi for Sx, Jxx, TLx, NDx, NDk1, Pxx, DBx gearboxes

Gírolía - Fólksbílar og fleiri.

75W/80

GL-4



Heiti	Vörunúmer
-------	-----------

GÍROLÍA 75W/80 GL-4 1 LTR	044 866895
---------------------------	------------

GÍROLÍA 75W/80 GL-4 20 LTR	044 866896
----------------------------	------------

Performance levels 1/2

API: GL-4, GL-3

API: GL-4 (tranself TRZ)

API: GL-4+ PSA B71 2330

API: GL-4+ (tranself NFJ)

API: GL-4+ (tranself NPF)

API: GL-4+ (tranself TRJ)

BMW MTF LT-2

Fiat 9.5555.0 – MZ1

Performance levels 2/2

Special Gear Oil MTF 94

Specail Honda MTF

Special Honda MTF-II

Volvo 97308, 97309

VW G 009 317, G 50



Gírolía - Fólksbílar og fleiri.

75W/80 GL-4



Heiti	Vörunúmer
Gírolía 75W-80 Tranself NFP 1 ltr	213974
Gírolía 75W-80 Tranself NFP 5 ltr	195576
Gírolía 75W-80 Tranself NFP 20 ltr	158488

APPROVALS

Specifications	Satisfies the international API GL-4 specification..
Manufacturers' approval	Officially approved and recommended by RENAULT for gearboxes JXX, TL4 and NDX.



Gírolía - Fólksbílar og fleiri.

75W/80 GL-4



Heiti	Vörunúmer
Gírolía 75W-80 Tranself NFJ 20L 20 ltr	158482

APPROVALS

Specifications	Satisfies the international API GL-4 specification..
Manufacturers' approval	Officially approved and recommended by RENAULT for gearboxes JXX, TL4 and NDX.



Gírolía - Fólksbílar og fleiri.

75W/80 GL-4



Heiti	Vörunúmer
Gírolía 75W-80 Traxium Gear 8 1L 1 ltr	214082
Gírolía 75W-80 Traxium Gear 8 20L 20 ltr	214099



KEY DATA

MANUAL TRANSMISSION OIL

SAE 75W-80

INTERNATIONAL STANDARDS

✓ API GL-4

MANUFACTURER APPROVALS

✓ PSA PEUGEOT CITROEN B71 2330



Gírolía - Vörubílar og fleiri.

75W/80

GL-4

Heiti

Vörunúmer



Gírolía 75W-80 Traxium Gear 8 FE
20 ltr

214084

KEY DATA

MANUAL TRANSMISSION OIL
SAE 75W-80
FUEL ECONOMY

INTERNATIONAL STANDARDS

- API GL-4

MANUFACTURER APPROVALS¹

- MAN 341 type E-3/Z-4
- ZF TE-ML 01L, 02L, 16K
- VOLVO 97307
- DAF
- IVECO MGS1



¹Please refer to car owner's manual



Gírolía - Vörubílar og fleiri.

75W/80

GL-4

Heiti

Vörunúmer



Gírolía 75W-80 Traxium Gear 9 FE
20 ltr

214138

KEY DATA



INTERNATIONAL STANDARDS

- API GL-4

MANUFACTURER APPROVALS

- ZF TE-ML 01E / 02E / 16P
- VOITH CLASS C
- VOLVO 97307
- MAN 341 type Z5
- MAN 341 type VR
- Mercedes-Benz Trucks: DTFR 13D120 (235.29)
- IVECO MGS2



Gírolía - Vörubílar og fleiri.

HD75W/80

GL-4

Heiti

Vörunúmer



GÍROLÍA HD PRO 75W/80 LD 1 LTR

044 868210

O.E.M. approvals

MAN 341 Z-4
ZF TE-ML 01L, 02L, 16K

Performance levels

API: GL-4
DAF*
Eaton*
Iveco*
MAN 341 E-3
Renault* (in accordance with Renault note technique B0032/2 Annex 3
ZF TE-ML 08, 13
Volvo 97305, 97307**
Suitable for use with ZF-Intarders

*Check owner's manual before use

**Pending



Gírolía - Fólksbílar og fleiri.

75W/90 GL-5

Heiti

Vörunúmer



GÍROLÍA 75W/90 "AXLE OIL" 1 Ltr 044 866890
GÍROLÍA 75W/90 "AXLE OIL" 20 Ltr 044 866901

Performance levels

API: GL-5



GÍROLÍA 75W/90 "AXLE LS" 1 Ltr 044 866904
LIMITED SLIP OLÍA
GÍROLÍA 75W/90 "AXLE LS" 20 Ltr 044 866905
LIMITED SLIP OLÍA

Performance levels

API: GL-5



Gírolía - Fólksbílar

75W/90

GL-4 - GL-5

Heiti

Vörunúmer

Full synthetic



GÍROLÍA TDL 75W-90 1L 044 879869

GÍROLÍA TDL 75W-90 20L 044 879868



Performance levels

API: GL-4, GL-5, MT-1
 BMW MTF LT-4
 Dexron MTF 75W-90
 Fiat 9.5550-MZ4
 Ford M2C-201-A
 Ford M2C200-B, C
 Ford N052145 VX00
 GM 89021807
 MB-235.72
 MB-235.8

Porsche 999.917.067.00
 SAAB MTF 0063
 Volvo 97309
 VW 501.50
 VW G 50
 VW G 052 145
 VW G 052 911
 ZF TE-ML 02B, 07A



Gírolía - Vörubílar-Vinnuvélar-Fólksbílar

75W/90

GL-4 - GL-5

Heiti

Vörunúmer

Full synthetic



GÍROLÍA TDL PRO 75W-90 1 LTR 044 868211

GÍROLÍA TDL PRO 75W-90 20 LTR 044 866932



Performance levels

API: GL-4, GL-5, MT-1
 Arvin Meritor Axles 0-76-N
 Mack GO-J
 MAN 341 type E3 (Eaton)
 MAN 342 type M3





Gírolía - Vörubílar-Vinnuvélar-Fólksbílar

75W/90

GL-4 - GL-5

Heiti

Vörunúmer



Gírolía 75W-90 Tranself SYN FE 20L
20 ltr

130089

Gírolía 75W-90 Tranself SYN FE 60L
60 ltr

103000

APPROVALS

Specifications

API GL-4 / GL-5
API MT-1

Manufacturers' approval

MAN 341 TYP E3, Z2
MAN 342 TYP S1
MB-Approval 235.8
ZF TE-ML 02B, 05B, 12L, 12N, 16F, 17B, 19C, 21B
VOLVO 97312
SCANIA STO 1.0

Meets the requirements of

Satisfies the requirements of van and truck manufacturers who require or allow a grade 75W-90 lubricant for their gearboxes and axles : DAF (first fill axle), IVECO, MACK, VOLVO, AUDI, VW
SAE J2360 PRI GL 0432, MIL-PRF-2105 E, MIL-L 2105 D



Gírolía - Vörubílar-Vinnuvélar

75W/90

GL-4 - GL-5

Heiti

Vörunúmer



Gírolía 75W-90 Traxium Dual 9 FE 1L
1 ltr

214145

Gírolía 75W-90 Traxium Dual 9 FE
20 ltr

214146

Gírolía 75W-90 Traxium Dual 9 FE
208 ltr

214148



KEY DATA

HIGH PERFORMANCE SYNTHETIC OIL
FOR GEARS

SAE 75W-90

FUEL ECONOMY

INTERNATIONAL STANDARDS

- API GL-4
- API GL-5
- API MT-1
- SAE J2360
- MIL-PRF 2105 E and MIL-L 2105 D

MANUFACTURER APPROVALS¹

- MB-Approval 235.8
- MAN 341 type Z-2
- MAN 342 type S-1
- SCANIA STO 1:0 (meet the requirement of)
- SCANIA STO 1:1 G
- SCANIA STO 2:0 A FS
- VOLVO 97312 / MACK GO-J Plus
- ZF TE-ML 02B, 05A, 12L, 12N, 16F, 17B, 19C, 21A
- MERITOR 076-N
- DAF
- IVECO RAS1



¹ Please refer to car owner's manual



Gírolía - Fólksbílar og fl.

75W/140



Heiti

Vörunúmer

Full synthetic

GÍROLÍA LS 75W/140 1 LTR

102 VV982

API, GL-4, GL-5

Extreme high/low temperature protection



Gírolía - Vörubílar og fl.

75W/140

GL-5



Heiti

Vörunúmer

GÍROLÍA 75W-140 TRANSELF SYN FE
1 LTR.

213871

APPROVALS

Specifications

API GL-5

Manufacturers' approval

SCANIA : STO 1.0 (gearboxes, high mileage)



Gírolía - Vörubílar og fl.

75W140

GL-5



Heiti

Vörunúmer

GÍROLÍA HD AXEL 75W/140 20LTR

044 879813

Performance levels

API: GL-5, MT-1

Scania STO 1:0



Gírolía - Vörubílar og fl.

75W140



Heiti

Vörunúmer

Gírolía 75W-140 Traxium Axle 8 FE
60 ltr

214133

KEY DATA

SYNTHETIC OIL FOR GEARS

SAE 75W-140

FUEL ECONOMY

INTERNATIONAL STANDARDS

- API GL-5
- MIL-L-2105 D

MANUFACTURER APPROVALS¹

- SCANIA STO 1:0



¹ Please refer to car owner's manual



Gírolía - Fólksbílar og fl.

80W/85

GL-4



Heiti

Vörunúmer

Gírolía 80W-85 Traxium Gear 7
20 ltr

201275

KEY DATA

GEAR OIL
SAE 80W-85

INTERNATIONAL STANDARDS

- API GL-4

MANUFACTURER APPROVALS¹

- MB-approval 235.1
- ZF TE-ML 17A



¹ Please refer to car owner's manual



Gírolía - Vörubílar-Vinnuvélar-Fólksbílar

80W/90

GL-5



Heiti

Vörunúmer

GÍROLÍA HD 80W/90 1 LTR GL-5

044 868214

GÍROLÍA HD 80W/90 5 LTR GL-5

044 866944

GÍROLÍA HD 80W/90 20 LTR GL-5

044 866945

GÍROLÍA HD 80W/90 208 LTR GL-5

044 866946

Performance levels

API: GL-5

ZF TE-ML 07A, 08, 24A



Gírolía - Vörubílar-Vinnuvélar-Fólksbílar

80W/90

GL-5

Fyrir driföxla.



Heiti

Vörunúmer

Gírolía 80W-90 Traxium Axle 7
1 ltr

214086

Gírolía 80W-90 Transmission Axle 7
20 ltr

214088

Gírolía 80W-90 Transmission Axle 7
208 ltr

214090

KEY DATA

MINERAL GEAR OIL

SAE 80W-90

INTERNATIONAL STANDARDS

- ✓ API GL-5

MANUFACTURER APPROVALS

- ✓ ZF TE-ML 12E, 17B, 19B
- ✓ MAN 342 type M-1



Gírolía - Vörubílar-Vinnuvélar-Fólksbílar

80W/90

GL-5 LS

Heiti

Fyrir læst drif

Vörunúmer



GÍROLÍA HD PRO LS 80W/90 1 LTR

044 868209

GÍROLÍA HD PRO LS 80W/90 20 LTR

044 866925

OEM Approvals:

ZF TE-ML 05C, 12C, 16E, 21C

Performance levels:

API GL-5, Arvin Meritor Axles



Gírolía - Fólksbílar og fl.

80W/90

GL-5 LS

Heiti

Fyrir læst drif

Vörunúmer



Gírolía 80W-90 Dynatrans LSD

229056

20 ltr

Gírolía 80W-90 Dynatrans DA LS

154941

208 ltr



SPECIFICATIONS AND APPROVALS

International specifications

API GL-5-LS

MIL.L. 2105D

Manufacturers' approvals

✓ ZF TE-ML 05C/12C/16E/21C

Meets the requirements of

- ✓ Worksite equipment: LIEBHERR, TEREX, VOLVO, CASE, JCB...
- ✓ Agricultural tractors : CLAAS-RENAULT, NEW-HOLLAND (NH-520B/520C), DEUTZ, STEYR, FORD (M2C 104A)
- ✓ 4 Wheel Drive passengers cars and all roads vehicles like : NISSAN, TOYOTA, GM,...



Gírolía - Fólksbílar og fl.

80W/90

GL-5 LS

Heiti

Fyrir læst drif

Vörunúmer



Gírolía 80W-90 HDH LS

F0005426

3,78 ltr

Features & Benefits

- Outstanding service
- Meets industry approvals
- Proven performance over millions of miles
- HDH 80W-90 LS is suitable for service in limited-slip differentials

Specifications

Meets Requirements of	75W-90	80W-90	85W-140	80W-90 LS
API GL-5	X	X	X	X
API MT-1	X	X	X	X
ZF TEML 07A & 08	X	X	X	X
FORD WSP-M2C197A	-	X	-	X



Gírolía - Vinnuvélar

85W/140

GL-5

Heiti

Vörunúmer



GÍROLÍA HD 85W/140 GL-5 20 L

044 866941

Performance levels

API: GL-5

ZF TE-ML 07A, 08



Gírolía - Vinnuvélar og fleira

85W/140

GL-5

Heiti

Vörunúmer



Gírolía 85W-140 HDH
18,9 Ltr

F0087140

Features & Benefits

- Outstanding service
- Meets industry approvals
- Proven performance over millions of miles
- HDH 80W-90 LS is suitable for service in limited-slip differentials

Specifications

Meets Requirements of	75W-90	80W-90	85W-140	80W-90 LS
API GL-5	X	X	X	X
API MT-1	X	X	X	X
ZF TEML 07A & 08	X	X	X	X
FORD WSP-M2C197A	-	X	-	X



Gírolía - Vinnuvélar og fleira
Fyrir driföxla.

85W/140

GL-5

Heiti

Vörunúmer



Gírolía 85W-140 Transmission Axle 7
20 ltr

214093

KEY DATA

MANUAL TRANSMISSION OIL

SAE 85W-140

INTERNATIONAL STANDARDS

- API GL-5

MANUFACTURER APPROVALS¹

- ZF TE-ML 05A, 12E, 16D, 21A
- IVECO RAM2



¹Please refer to car owner's manual



Gírolía

10W



Heiti

Vörunúmer

Gírolía 10W DT Transmission 20 Ltr

044 819582

Gírolía 10W DT Transmission 208 Ltr

044 17818

Performance levels

API CF, MT-1
Caterpillar TO-4
Allison C-4
ZF TE-ML 03C, 07F
Komatsu KES 07.868.1
Caterpillar TO-2
Eaton Fuller*
Dana*
Euclid*

*for applications where a TO-4 is needed



Gírolía - Einþykktarolía

10W



Heiti

Vörunúmer

Gírolía 10W Rubia SX
20 ltr

209456

Gírolía 10W Rubia SX
208 ltr

209455

SPECIFICATIONS AND APPROVALS

International standards :

API CF / SF

APPLICATIONS

All Hydraulic circuits, Gearboxes and Engines when the manufacturer requires a single-grade "Engine oil" type lubricant.

The viscosity grade has to be chosen according to the following table :

	10W	20W-20	30	40	50
Hydraulic circuits	✓	✓	✓	✓ (HT)	Not advised
Gearboxes	✓ (LT)	✓	✓	✓	✓ (HT)
Engines	Not advised	✓ (LT)	✓	✓	✓ (HT)

HT = High ambient Temperature (> 40°C)

LT = Low ambient Temperature (< -25°C)



Gírolía - Einþykktarolía

30W



Heiti

Vörunúmer

Gírolía 30W DT Transmission 20ltr
20 ltr

044 756754

O.E.M. Approvals

ZF TE-ML 03C
ZF TE-ML 07F

Performance levels

API CF / CF-2 / MT-1
Caterpillar TO-4
Allison C-4
Komatsu (KES 07 868.1)



Gírolía - Einþykktarolía

SAE 80W

5 ltr Brúsi



Heiti

Vörunúmer

Gírolía 80W Heavy Duty GL-4

044 867053

5 Ltr Brúsi

Performance levels

API: GL-4

MAN 341 Type E1(Eaton transmissions)

MAN 341 Type Z2

ZF TE-ML 02B, 06L, 08, 16A, 17A, 19A, 19C.



Sjálfskiptiolía - Fólksbílar

ATF PRO



O.E.M. approvals

MB-Approval 236.15

Performance levels

MB NAG-2+ transmissions

MB 7-speed automatic transmission series Tronic Plus

Heiti

Vörunúmer

Sjálfskiptivökvi ATF PRO 1 Ltr
236.14

044 866737

Sjálfskiptivökvi ATF PRO 20 Ltr
236.14

044 866738

Sjálfskiptivökvi ATF PRO 1 Ltr
236.15

044 866881

O.E.M. approvals

MB-Approval 236.14

Performance levels

MB 236.12

MB NAG-2 transmissions

MB 7-speed automatic transmission series 722.9

MB 5-speed automatic transmission series 722.6

Ssang Yong passenger cars with MB automatic transmissions

Valvoline™ ATF Pro 236.14

Premium full synthetic high performance automatic transmission fluid for passenger cars, vans, LCV, and SUV.

Sjálfskiptiolía - Fólksbílar og fleiri.

ATF PRO+4



Heiti

Vörunúmer

Sjálfskiptivökvi ATF PRO+4 1 Ltr

044 866736

O.E.M. approvals

Chrysler MS9602 (ATF +4®)

Chrysler MS7176E (ATF +3®)

Chrysler MS7176D (ATF +2®)

Chrysler MS7176 (ATF +®)

Performance levels

Recommended for use where Fiat 9.55550-AV4 is specified

Sjálfskiptiolía - Fólksbílar og fleiri.

ATF

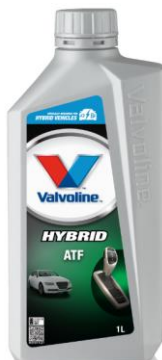

Heiti

Vörunúmer

Sjálfskiptivökvi Hybrid ATF 1 Ltr

044 892451

Aisin Warner	Hyundai	Mercedes-Benz	Volvo
BMW	Jaguar	Mini Cooper	VW
Chrysler	JASO	Mitsubishi	VW / Audi
Ford	KIA	Nissan / Infiniti	
GM	Landrover	Subaru	
Honda / Acura	Mazda	Toyota / Lexus	

Sjálfskiptiolía - Fólksbílar- vörubílar-Vinnuvélar

ATF / CVT



Heiti

Vörunúmer

Sjálfskiptivökvi ATF CVT 1 Ltr

044 895132

Sjálfskiptivökvi ATF CVT 5 Ltr

044 895133

Sjálfskiptivökvi ATF CVT 20 Ltr

044 895134

Sjálfskiptivökvi ATF CVT 208 Ltr

044 895136

Acura		Daewoo		Isuzu Besco	
ATF-Z1		LT 71141		ATF-II	
AW-1/ AW-2		AMMIX ATF D-I I		ATF-III	
Aisin Warner		AMMIX ATFD-III SP		ATF-SP	
JWS 3309		Fiat		ATF LT71141, ZF 5HP24	
JWS 3324		T-IV type, JWS 3309		ATF 3403, JLM20238	
C-3		ESP-M2C166H, XL-12		ATF3403-M115	
C-4		FNR5		Jaguar Fluid 8432	
Allison		M2C138CJ		JLM 20292	
TES-295		M2C166H		JLM 21044	
TES-389		MERCON® LV (FF-WSS-M2C-938A/SF, XR-10 QLV)			
American Motors		MERCON® SR		M315-2013 1A	
ATF +3		MERCON®V		M315-2013 1A-LV	
ATF +4		MERCON®		M315-2013 2A	
Applo/IKC		Ford		Jeep	
ATF RED 1		Type F		ATF+3, +4	
RED 1K		Type G		ATF Red 1	
Audi		WSSM2C138CJ, 166H		ATF SP-II	
LT71141		WSS M2C 922A1, 924A (XT-8-QAW) JWS 3309		ATF SP-III	
		XT-2-QDX(M)		ATF SP-IV	
		XT-2-QSM(Syn)		ATF SP-IV M	
		XT-5-QM(V)		LR0022460	
		XT-6-QSP or-DSP (SP)		LR023288	
		XT-9-QMMF5		TYK500050	
		Fuso		Lexus	
		ATF-A4		JWS 3309	
		ATF-II		339 Type D	
		ATF-SPIII		339 Type F	
				339 V2	
				339 Z1	
				339 Z2	
				339 Z3	
				MAN 339 V1	
				Maserati	
				231603	
				Mazda	
				ATF 3317	
				ATF F-1	
				ATF FZ	
				ATF M-III	
				ATF M-V	
				ATF N-1	
				ATF S-1	
				D-II	
				236.1	
				236.11	
				236.12	
				236.14	
				236.15	
				236.17	
				236.2	
				236.3	
				236.41	
				236.6	
				236.7	
				236.8	
				236.9	
				236.91	
				ZF 4HP20	
				Mini Cooper	
				T-IV	
				Miscellaneous	
				M1375.6	
				Mitsubishi	
				Diaqueen ATF PA	
				Diaqueen AW	
				Diaqueen J2	
				Diaqueen J3	
				Diaqueen SK	
				Diaqueen SP-II	
				Diaqueen SP-III Diaqueen SP-IV	
Audi/VW		GM		MB (Mercedes Benz)	
G 052 025-A2		1940700		236.1	
G 052 162-A1/A2		1940767		236.11	
G 052 990/ G 052 055		12378515		236.12	
G053 025-A2		21005966		236.14	
G 055 005-A/A1/A2		22717466		236.15	
G 055 025A2		88900925		236.17	
G 055 162-A2, -A6		93160393		236.2	
G 055 540-A2		GM Autotrak II		236.3	
Bentley		GM DEXRON - VI		236.41	
G 060 162		GM DEXRON - II		236.6	
PY112995PA		GM DEXRON - IID		236.7	
		GM DEXRON - IIE		236.8	
		GM DEXRON - IIIG		236.9	
		GM DEXRON - IIIH		236.91	
		GM TASA		ZF 4HP20	
		88863400			
		88863401			
		AW-1			
		GM/GMC/Opel/ Saturn			
		88863400			
		88863401			
		AW-1			
		Hino			
		Blue Ribbon ATF			
		ATF-Z1 (except in CVTs)			
		Honda			
		DW-1			
		Type 3.0 and 3.1			
		040000C90SG			
		Dex-II/ sp-II			
		NWS 9638			
		SP-III			
		SP-IV			
		SP-IV H			
		SP-IV M			
		SP-IV-RR			
		WS3314			
		Idemitsu			
		K17 3100 PL085			
		Isuzu			
		08200-9001			
		SCS Fluid			
Chrysler/Dodge/Jeep					
05127382AA					
68043742AA					
68157995AA					
NAG 1					

Sjálfskiptiolía - Fólksbílar- vörubílar-Vinnuvélar
ATF / CVT

Nissan	Matic Fluid C	VW (Volkswagen)	G US 000 162	ZF	3, 4, & 6 speed transmissions
	Matic Fluid D		G 052 025-A2		TE-ML 02F
	Matic Fluid J		G 052 055		TE-ML 03D
	Matic Fluid K		G 052 162-A1/A2 (ZF Lifeguardfluid 5)		TE-ML 04D
	Matic Fluid S		G 052 990		TE-ML 05L
Matic Fluid W	G 053 025-A2	TE-ML 09			
Opel/GM	9986195	VW (Volkswagen)	G 055 005-A/A1/A2 (ZF Lifeguardfluid 6)		TE-ML 11 A, 11B
	88900925		G 055 025 A2 (JWS 3309)		TE-ML 14A
	19 40 700		G 055 162-A2, -A6 (ZF Lifeguardfluid 6+)		TE-ML 14B
	19 40 767		G 055 540-A2		TE-ML 14C
	21005966 Transaxle		G 060 162 (ZF Lifeguardfluid 8)	TE-ML 16N	
Peugeot/Citroën	2.217.466		G-053 162 A1 (ZF Lifeguardfluid 5)	TE-ML 17C	
	Z000169756		LT71141	TE-ML 21L	
Peugeot	ZF 4HP20		TL 521 62	ZF 8 speed transmissions	
Porsche	000 043 205 09	OEM	CVT Application		
	000 043 205 28	Audi	Multitronic		
	000 043 304 00	BMW Mini Cooper	EZL 799/ 83 22 0 136 376/ 83 22 0 429 154		
	999 917 547 00 (A2)	Chery	CVT		
	ATF 3403-M115,	Chrysler/Dodge/Jeep	CVT+4		
	T-IV (JWS 3309)		NS-2		
	Z000169756	Daihatsu	AMMIX CVTF DFE		
ZF 5HP19FL, ZF 5HP20, LT71141	AMMIX CVT Fluid DC				
Renault	DPO/AL4	Ford	AMMIX CVT Fluid DFC		
	Matic D2		Fluid TC		
	Samsung SATF-D		CFT		
Saab	93.160.393	Fujijyuuko	CVT 30 or WSS-M2C933A		
	93.165.147		MERCON® C		
	T-IV (JWS 3309)		WSS-M2C-199A		
Saturn	T-IV (JWS 3309)	GM/Saturn	i-CVTF FG		
	T-IV (JWS 3309)	GM	DEX-CVT		
Subaru	All vehicles		GM VT40		
	DSIH 5M-66		GM Dexron HP CVT, GM 19355873, GM19355874		
	ATF		GM 1940713		
	ATF 5AT		GM 1940714		
	ATF HP	GM 192609800			
Suzuki	Dexron-II	Honda	GM 19299096		
	K0140Y0700		CVTF I-Green 2		
	AT OIL 5D06		Multimatic HMMF (without starting clutch)		
	ATF 2326		HCF2		
	ATF 2384K		Z-1 (CVT model, without starting clutch)		
	ATF 3314		Honda CVT		
	ATF 3317		CVT-J1		
ATF AW-1	Hyundai/Kia	SP III (CVT model)			
JWS 3309		Idemitsu	CVTS-EX1		
Toyota	ATF D-II	Lexus	Fluid TC, Fluid FE		
	ATF D-III	Mazda	JWS3320		
	ATF T-III	MB (Mercedes Benz)	236 20/ CVT28		
	ATF T-IV	MG Rover	EM-CVT		
	ATF Type T	Mini Cooper	EZL/EZL 799A.ZF CVT V1		
Vickers	ATF WS	Mitsubishi	CVTF-J1 (MMC Diaqueen CVT Fluid J1>		
	M2950-S, I-286-S		CVTF-J4 and -J4+ (MMC Diaqueen CVT Fluid J4 and J4+)		
Voith	55.6335. XX (G607)		Nissan	Diaqueen SP-III (CVT model only)	
	55.6336. XX (G13636)	CVTF Eco J4			
Volvo	Service Bulletin #013 and #118	Punch	KTF-1		
	97325		NS-1, -2, -3		
	97335	Renault	N-CVT		
	CE 97340		CVT		
	CE 97341	Rover	ElfMaticCVT		
	CE 97342		Unipart Superflow CVT (without starting clutch)		
	PN 1161521	Subaru	ECVT		
	PN 1161540/1161640		iCVT		
	STD 1273 41		iCVT FG		
	VW (Volkswagen)	5 HP (ZF 5 HP 30) 5HP(18FL, 30) 5HP (19FL, 24A)	Suzuki	Lineartronic chain CVT and CVT II Fluid	
Lineartronic High Torque (HT) CVT Fluid, CV-30, K0425Y0710					
Toyota			NS-2		
			CVTF TC		
			CVTF 3320		
			CVT Green 1 & 2		
			CVT Green 1V		
Volvo			NS-2		
			CVTF 4401		
VW/Audi			CVTF FE		
			CVTF TC		
VW/Audi			Prius (power split CVT, Toyota WS hybrid planetary gear set with a belt driven CVT)		
			jCVT 4959		
			G 055 190		
VW/Audi			TL 521 16 (G 052 516)		
			TL 521 80 (G 052 180)		
			TL 521 90 (G 052 190)		



Sjálfskiptiolía - Fólksbílar- og fleira

Multi Vehicle

Heiti

Vörunúmer



Sjálfskiptivökvi Transflo MV
946 ml

F0076315

Specifications

Meets the requirements of

High Viscosity Specifications

Acura ATF-Z1
Aisin Warner JWS 3309 (T-IV)
Allison C-3 & C-4
American Motors ATF +3 (MS 7176E)
ATF RED1, RED1K
Audi 5 HP LT71141 (ZF 5 HP 18FL/19FL/24A)
Audi G 052 162-A1/A2
Audi G 052 025-A2
Audi/VW G 052 990
Audi G 052 055
Audi G 053 025-A2
Audi G 055 025 A2 (JWS 3309)
AW-1
Bosch TE-ML 09
BMW JWS 3309 (T-IV)
BMW LA2634
BMW 7045E
BMW ETL-8072B
BMW MINI
CAT TO-2
Chrysler ATF+2, ATF+3 (MS 7176E)
Chrysler/Dodge MOPAR AS 68 RC (T-IV) JWS 3309
Daewoo LT 71141
Daihatsu AMMIX ATF D-II, D-III SP
Daihatsu Friend ATF D-III
Esso LT 71141
FIAT T-IV Type JWS 3309
Ford MERCON®
Ford MERCON®-V
Ford FNR5
Ford M2C138CJ
Ford M2C166H
Ford WSS M2C 922A1, 924A (XT-8-QAW) JWS 3309
Fuso ATF-II
Fuso ATF-SP II
Fuso ATF- A4
GM9986195 (Aisin AW, JWS 3309)
GM TASA
GM DEXRON® II, DEXRON® IID, DEXRON® IIE, DEXRON® IIIG, DEXRON® IIH

Low Viscosity Specifications

Honda DW-1
Hyundai/Kia SP-IV
Hyundai/Kia SP-IV M
Hyundai/Kia SP-IV RR
Hyundai/Kia NWS 9638
JWS 3324 (WS)
Mazda ATF FZ
Mitsubishi Diaqueen SP-IV
Mitsubishi Diaqueen J3
Mitsubishi Diaqueen ATF PA
Nissan Matic Fluid S
Saab 93 165 147
Toyota ATF WS

High Viscosity Specifications

Hino Blue Ribbon ATF
Honda ATF- Z1 (not for use in CVT)
Honda ATF Ultra II
Honda DW-1
Hyundai/Kia Dex-II/SP-II
Hyundai/Kia SP-III
Hyundai/Kia JWS 3314
Hyundai/Kia JWS 9683
Hyundai/Kia 040000C90SG
Idemitsu K17
ISUZU BESCO ATF SP
ISUZU SCS Fluid
ISUZU 08200-9001
ISUZU BESCO ATF-II, BESCO ATF-III
Jaguar ATF 3403 M115
Jaguar ATF LT71141, ZF 5HP24
Jaguar JLM 20292
Jaguar JLM 21044
Jaguar Fluid 8432
JASO M315-2013 1A
JASO MS315-2013 2A
JEEP ATF +3
Lexus JWS 3309
KIA ATF SP-II, SP-III, SP-IV, SP-IVM, Red 1
Mazda ATF D-II
Mazda ATF M-III, ATF M-V
Mazda ATF F-1
Mazda ATF S-1
Mazda ATF N-1
Mazda ATF 3317
Mini Cooper T-IV
Mitsubishi Diaqueen SK
Mitsubishi Diaqueen SP-II, SP-III
Mitsubishi Diaqueen AW
Mitsubishi Diaqueen J2
NAG 1 (Chrysler, Jeep, Cherokee)
Nissan Matic Fluid C
Nissan Matic Fluid D
Nissan Matic Fluid J
Nissan Matic Fluid K
Nissan Matic Fluid N4
Opel

Transfer Case Applications

Ford MERCON®-V
Ford Part#XL-12
GM IID, IIH

High Viscosity Specifications

Peugot/Citreon Z 000169756
Porsche T-IV (JWS 3309)
Renault Samsung SATF-D
Ssang young DSIH 5M-66
Saab T-IV (JWS 3309)
Saturn T-IV (JWS 3309)
Scion
Subaru ATF
Subaru ATF for Vivio 3 speed
Subaru ATF 5AT
Subaru ATF, ATF HP
Subaru K0140Y0700
Suzuki AT OIL 5006
Suzuki ATF 2326
Suzuki ATF 2384K
Suzuki ATF 3309
Suzuki ATF 3314
Suzuki ATF 3317
Suzuki ATF AW-1
Texaco 7045-E
Texaco 8072B
Texaco N402
Toyota ATF D-II, ATF D-III
Toyota ATF T-III, ATF T-IV
Vickers M2950-S, I-286-S
Volvo CE 97340
Volvo 97325
Volvo 97335
VW G US 000 162
VW G-055-025 A2 (JWS 3309)
ZF-TE-ML 05L
ZF-TE-ML 09
ZF-TE-ML 11A, 11B
ZF TE-ML 21L

Power Steering Applications

Chrysler MS-1872
Chrysler MS 5931
Chrysler MS 9602
Ford M2C195-A
GM P/N 89021184
GM P/N 1052884 (GM 9985010)
GM P/N 12345866 (GM 9985835)
Hyundai/Kia PSF-3
Mercedes-Benz 236.3 (P/N 000 989 88 03)
Mitsubishi PS fluid, Diamond SP-III
Nissan PSF-II
Saab P/N 45 30 09 800
Subaru P/N K0209A0080
ZF TE-ML 09



Sjálfskiptiolía - Fólksbílar og fleiri.

ATF MAZDA



Heiti

Vörunúmer

Sjálfskiptivökvi Mazda ATF FZ
1 Ltr

214197

APPLICATION

- Original fluid
- Fluid tested and recommended by Mazda Corporation for automatic transmission vehicles equipped with SKYACTIV Technology (Mazda CX-5).

SPECIFICATIONS

- This fluid has been tested and approved by Mazda Corporation. Meets the requirements of SKYACTIV Technology.



Sjálfskiptiolía - Fólksbílar og fleiri.

ATF MAZDA



Heiti

Vörunúmer

Sjálfskiptivökvi Mazda ATF A7
1 Ltr

219748

APPLICATION

- Original Automatic Transmission Fluid
 - Automatic transmission fluid tested and recommended by Mazda Motor Corporation for SKYACTIV-X vehicles equipped with automatic transmissions. Formulated and approved to meet the specific requirements of Mazda vehicles with SKYACTIV-X engines.

SPECIFICATIONS

- This oil has been developed for and approved by Mazda Motor Corporation and meets the requirements of SKYACTIV-X technology.



Sjálfskiptiolía - Fólksbílar og fleiri.

RENAULT

Stýrisvökvi



RENAULT



Heiti

Vörunúmer

Sjálfskiptivökvi Renaultmatic D2 Syn
1 Ltr

1135507

PERFORMANCES LEVELS

OEM-Approved

- ✓ Renault approval for power steering
- Special fluid for automatic and hydrostatic transmission systems, recommended for all RENAULT cars and vans.
- Do not use ELF RENAULTMATIC D2 in automatic transmission and power-assisted steering systems of other brands of vehicle..

Meets the requirements

- ✓ GM Dexron IID



Sjálfskiptiolía - Fólksbílar og fleiri.

CVT



Heiti

Vörunúmer

Sjálfskiptivökvi Elfmatic CVT
1 Ltr

194761

PERFORMANCES LEVELS

OEM-Approved

- ✓ Renault CVT FK/CK/DK

APPLICATIONS

- ELMATIC CVT is recommended for RENAULT CVT Transmissions
- ELMATIC CVT is recommended for JATCO CVT Transmissions
- Do not use another CVT fluid for Renault Application
- Do not use this fluid for NISSAN CVT NS-1
- This oil is compatible with NISSAN CVT NS-2



Sjálfskiptiolía - Fólksbílar og fleiri.

CVT



Heiti

Vörunúmer

Sjálfskiptivökvi Fluidmatic CVT MV
1 ltr

214024

KEY DATA

SUITABLE FOR:

- Audi/Volkswagen: TL 521 80 (G 052 180 A2) / TL 521 16 (G 052 516)
- (G 052 516) / Audi Multitronic
- BMW mini Cooper : 83 22 0136 376/ 83 22 0 429 154
- Daihatsu AMMIX CVTF DFE / CVT Fluid DC & DFC & TC
- Punch CVTF-EX1
- Jatco CVT 8 Hybrid
- HONDA : HMMF, HCF2, Z-1
- HYUNDAI: CVT-1, SP III-CVT
- MAZDA: JWS 3320
- MITSUBISHI: CVTF-J1, CVTF J-4 / J-4+, SP III CVT, ECO J4
- NISSAN NS-1, NS-2/2V, NS-3
- RENAULT CVT CK/SK/FK
- SUBARU iCVT, iCVT FG, ECVT, NS-2, Lineartronic chain CVT and CVT II Fluid, K0425Y0710 & K0425Y0711, Subaru Lineartronic High Torque (HT) CVT Fluid, CV-30, K0421Y0700
- SUZUKI CVT green 1&2 / 1V / CVTF TC/3320/4401 NS-2
- TOYOTA : CVTF TV/ CVTF FE THS-II





Sjálfskiptiolía - Fólksbílar og fleiri.

DCT



Heiti	Vörunúmer
Dual Clutch Transmission	
Sjálfskiptivökvi DCT 1 Ltr	044 866909
Sjálfskiptivökvi DCT 5 Ltr	044 868207
Sjálfskiptivökvi DCT Maxlife 1 Ltr	044 821636

Performance levels 1/2

VW TL 521 82
 VW G 052 182, G 052 529
 BMW 83 222 148 – 578, 579
 BMW 83 222 147 – 477
 BMW 83 220 440214

Performance levels 2/2

PSA 9734.S2
 Ford M2C936A
 MB-236.21
 Mitsubishi Dia-Queen SSTF-1
 Porsche Oil No. 999.917.080.00
 Volvo 1161838, 1161839



Sjálfskiptiolía - Fólksbílar og fleiri.

DCT



Heiti	Vörunúmer
Sjálfskiptivökvi Fluidmatic DCT MV 1 ltr	214012

KEY DATA

MEETS THE REQUIREMENTS¹:

- Audi/Volkswagen TL 052 182 / TL 052 529
- Ford WSS-M2C 936-A
- Mercedes-Benz MB 236.21

SUITABLE FOR:

- Audi/Volkswagen: DQ250, DQ500, DL501, G 055 529, G052 182, G052 529
- BMW: P/N 83 22 2 148 578 / 83 22 2 148 579 /83 22 0 440 214 / 83 22 2 147 477
- Citroën: 6DCT451
- Ford / Getrag: 6DCT450, 6DCT451, 7DCT300
- Mercedes-Benz: F-DCT350, F-DCT500
- Volvo: P/N 1161838



¹ Please refer to car owner's manual



Sjálfskiptiolía - Fólksbílar og fleiri.

HYBRID



DCT

Heiti

Vörunúmer

Sjálfskiptivökvi Hybrid DCT 1 Ltr

044 892454

Performance levels 1/2

BMW: 6-speed DCT, DCTF-1+, MTF LT-5, Drivelogic 7-speed/ DCTF-1

Borg Warner

Bugatti Veyron

BOT 341, 450

Chrysler: 68044345 EA & GA, Powershift 6-speed

Ferrari 7-speed /TE DCT-3

Ford/Nissan Powershift 6-speed (GFT) / Ford WSS-M2C936A, part # 1490763/1490761

Mitsubishi TC-SST 6-speed (GFT) / MZ320065 DiaQueen SSTF-1

PDK transmission oil for ZF (DCT Transmission Oil for 7F)

Performance levels 2/2

Peugeot/Citroen DCS 6-speed (GFT)/9734.S2

Renault EDC 6-speed, EDC-7 speed, Talisman R7D

Volvo Powershift 6-speed (GFT)/1161838/1161839

VW (Audi, Seat, Skoda) 6-speed

VW G 055 536

VW/Audi G 055 529

VW/Audi TL 521 82/ G 052 182 A2 or A6

VW/Audi TL 52529/ G 052 529 A2 or A6/ DSG7/ S-Tronic 7/ 7 speed VW (Audi, Seat, Skoda)

ZF/Porsche Oil #999.917.080.00

Sjálfskiptiolía - Fólksbílar og fleiri.



DEX III

Heiti

Vörunúmer

Sjálfskiptivökvi Transflo 18,9 L
18,9 Ltr

F0082240



Specifications

Meets Requirements Of

Allison C-3 & C-4
Allison TES-389
American Motors ATF +3 (MS 7176-E)
Audi G 052 162-A1/A2 (ZF Lifeguard 5)
BMW 7045E
BMW ETL-8072B
BMW LA2634
CAT TO-2
Chrysler ATF+2, +3
Ford MERCON®
Ford WSS M2C 183CJ, 166H
GM DEXRON®II
GM DEXRON®IID
GM DEXRON®III
GM DEXRON®IIIE
GM DEXRON®IIIG
GM DEXRON®IIIH
GM TASA

Hyundai/Kia DEX-II/SP-II
Jaguar JLM 20292
Jaguar JLM 20238
Mazda ATF M-III
Mazda ATF F-I
MB ZF 4HP20
NAG 1 (Chrysler, Jeep, Cherokee)
Opel/GM 19 40 700, 19 40 767, 21005966
Transaxle, 22 17466
Peugot/Citroen Z 000169756, AL4 Automatic gearbox oil (#9730.AE)
Porsche 000 043 205 09, 999 917 547 00, Z 000169756

Renault Matic D2
Renault DPO/AL4
Volvo CE 97340
Volvo 97325
Volvo 97335
Vickers M2950-S, I-286-S
VW G US 000 162
ZF TE-ML 05L
ZF TE-ML 09
ZF TE-ML 21L



Sjálfskiptiolía - Fólksbílar

DEX/MEX



Heiti	Vörunúmer
Sjálfskiptivökvi DEX/MERC 1 Ltr	044 866913
Sjálfskiptivökvi DEX/MERC 20 Ltr	044 866912
Sjálfskiptivökvi DEX/MERC 208 Ltr	044 866911

Performance levels
GM Dexron III
Ford Mercon
Allison C-4
Volvo 97325, 97335, 97340
ZF TE-ML 05L, 09, 11A, 11B



Sjálfskiptiolía - Fólksbílar og fleira.

DEX III



Heiti	Vörunúmer
Sjálfskiptivökvi ATF DEX III - rauður 205 Ltr	020000050

Navi-Guard Multi -Purpose ATF er hágæða sjálfskiptivökvi sem var hannaður fyrir rafstýrðar sjálfskiptingar. Hentar á GM og Ford.

SPECIFICATIONS

ALLISON C-4, TES-389™ • CATERPILLAR TO-2 • DEXRON® III-H (G-F) II-E (C-D) • FORD MERCON®, M2C138CJ, M2C166H



Sjálfskiptiolía - Fólksbílar og fleira.

DEX III



Heiti	Vörunúmer
Sjálfskiptivökvi Elfmatic G3 1 ltr	213861
Sjálfskiptivökvi Elfmatic G3 208 ltr	156933

PERFORMANCES LEVELS

OEM-Approved

- ✓ Mercedes MB 236.9
- ✓ Volvo 97341
- ✓ MAN 339 Type V1/Z1/L1
- ✓ Voith H55.6335.xx
- ✓ ZF TE-ML 04D/14A

Meets the requirements

- ✓ GM Dexron IIIG / IIIH
- ✓ Ford Mercon

Suitable for

- ✓ Allison C4



Sjálfskiptiolía - Fólksbílar- Vörubílar-Fleiri



Heiti	Vörunúmer
Sjálfskiptivökvi Fluide XLD FE 1 ltr	213821
Sjálfskiptivökvi Fluide XLD FE 20 ltr	213720
Sjálfskiptivökvi Fluide XLD FE 208 ltr	213721

Extra Long Drain Automatic Transmission Fluid

PERFORMANCE LEVELS

OEM-approved:

- ✓ ZF TE-ML 04D/14B/16L/20B
- ✓ VOITH H55.6336.xx
- ✓ MAN 339 Type V2/Z2
- ✓ Mercedes-Benz MB-Approval 236.6
- ✓ Allison C4 (n° 32802009)
- ✓ Volvo 97341

Meets the requirements:

- ✓ MAN 339 Type Z3
- ✓ GM Dexron IIIH
- ✓ ZF TE-ML 02F
- ✓ Mercedes-Benz MB 236.91
- ✓ VW TL 52162
- ✓ Ford Mercon/Mercon V
- ✓ JASO 1A
- ✓ Toyota T-IV
- ✓ Hyundai, Kia, Mitsubishi SP-III
- ✓ Honda Z-1
- ✓ Mazda M-III / M-V
- ✓ Aisin Warner JWS 3309

Suitable for:

- ✓ ZF TE-ML 11B
- ✓ Nissan: AT-Matic D, J, K



Sjálfskiptiolía - Vörubílar-Fleiri



Heiti	Vörunúmer
Sjálfskiptivökvi Fluidmatic D3 1 ltr	213757
Sjálfskiptivökvi Fluidmatic D3 20 ltr	213658

KEY DATA

MANUFACTURER APPROVALS¹:

- Mercedes MB-Approval 236.9
- Volvo 97341
- MAN 339 Type V1/Z1/L1
- Voith H55.6335.xx
- ZF TE-ML 04D/14A/11B

MEETS THE REQUIREMENTS:

- GM Dexron III G / III H
- Ford Mercon

SUITABLE FOR:

- Allison C4



¹Please refer to car owner's manual



Gírkassaolía - Glussi



Heiti

Vörunúmer

Glussi Speedmatic
1 ltr

148385



Synthetic fluid for automated manual transmissions

APPLICATIONS

- Fits automated gearboxes which shifting circuit is separated and uses a specific oil
- Is especially recommended for Selespeed ® gearboxes and for certain light duty trucks automation devices

APPROVALS

MATCHES MAJOR MANUFACTURERS REQUIREMENTS

Manufacturers' approval

Renault : Trafic & Master automated gearbox PA6 (Approved oil n°7711228107)

Other application field

Opel : Movano and Vivaro automated gearbox
Alfa Romeo - Fiat : vehicles with Selespeed device

PERFORMANCES AND CUSTOMER BENEFITS



Stýrisvökvi - Fólksbílar

Fyrir Citroen

Heiti

Vörunúmer



Stýrisvökvi Fluide DA
1 ltr
Litur Orange.

213756

APPLICATIONS

Synthetic fluid of **orange** colour for the hydraulic system of Citroën cars equipped with "HYDRActive 3"
Do not use when a mineral fluid of fluo **green** colour is requested (LHM Plus)

CUSTOMER BENEFITS

- Super multigrade fluid
- Exceptionally high viscosity index
- Very low pour point
- Very high thermal stability
- Very good protection against wear and corrosion
- Excellent lubricating properties

SPECIFICATIONS

- Manufacturer Approvals: **PSA S71 2710 and MAN 3289**

Stýrisvökvi - Fólksbílar - Vörubílar - Fleiri



Heiti

Vörunúmer

Stýrisvökvi Synpower 1 Ltr
Power steering

044 18320

Performance levels

VW TL 52146 (G 002000)
VW G004000M2
MB 345.0
GM B 040 0070
MAN M 3289
Volvo 1161529
AUDI*, BMW*, SAAB*, Porsche*
Skoda*, Fendt*, FORD*, ZF*

* This product is **not** suitable for all the models of the brand. Check owners' manual before use.

Glussi og mótrolía

HD 10W



HEITI

VÖRUNÚMER

GLUSSI/OLÍA HD10W 20 LTR
GLUSSI/OLÍA HD10W 208LTR

044 12606
044 608865

Performance levels

API: CF



HD Engine Oil

SAE Viscosity Grade	10W
Viscosity, mm²/s @ 100 °C. ASTM D-445	6,5
Viscosity, mm²/s @ 40 °C. ASTM D-445	39
Viscosity Index ASTM D-2270	118
Viscosity, mPa.s -25°C. ASTM D-5293	<7000
TBN, mg KOH/g ASTM D-2896	7,2
Pour Point, °C ASTM D-5949	-42
Specific Gravity @ 15.6°C. ASTM D-4052	0,868
Flash Point, COC, °C. ASTM D-92	218

Applications

Suitable for heavy-duty engines where single grade motor oils are recommended.

Specially engineered for use in service fleets where it helps prevent formation of sludge caused by frequent stop-and-go driving.

Can also be used, in some cases, as hydraulic oil or gear oil where specified by the manufacturer of the machine.

Can be used as hydraulic oil with the ISO 32 qualification.



Glussi

AW15



Heiti

Vörunúmer

Fyrir flórsköfur

Glussi 15 flórsköfuglusi Irving Oil
18,9 Ltr

F0087640

Specifications

Meets Requirements Of:	15
DIN 51524-2 (HLP)	✓
ASTM D6158 (HM)	✓
ISO 11158 (HM)	✓
SAE MS 1004 (HM)	✓
Parker (formerly Denison) HF-0, HF-1, HF-2	-
Eaton M-2950-S, I-286-S3 and 35VQ25 (Obsolete)	-
Bosch Rexroth RE 90220, 90240 (Obsolete)	✓



Glussi

22



Heiti

Vörunúmer

Glussi 22 Total Equivis ZS lyktarlaus 112485
20 ltr polir hitastig frá -30°C. upp í 100°C
Lyktarlaus glussi sem hentar vel fyrir lyftur í húsum.

SPECIFICATIONS

International specifications.

- AFNOR NF E 48-603 HV
- VICKERS I-286-S, M-2950-S
- ISO 6743/4 CATEGORY HV
- CINCINNATI MILACRON P68, P69, P70
- DIN 51524 PART 3 CATEGORY HVLP



Glussi

22



Heiti

Vörunúmer

Glussi 22 Total Azolla ZS 20L 112464
20 ltr
Glussi 22 Total Azolla ZS 20L 110473
208 ltr

SPECIFICATIONS

International specifications

OEM

- AFNOR NF E 48-603 HM
- ISO 6743/4 HM
- DIN 51524 P2 HLP
- CINCINNATI MILACRON P68, P69, P70
- VICKERS M-2950S, I-286
- DENISON HF0, HF1, HF2 (T6H20C)



Glussi

HLP-32



Heiti

Vörunúmer

GLUSSI VAL HLP 32 20 LTR 044 878269
GLUSSI VAL HLP 32 208 LTR 044 854005

Performance levels
DIN 51524 (part 2)





Glussi

32

Heiti

Vörunúmer



Glussi 32 Total Azolla ZS 20L
20 ltr

110475

Glussi 32 Total Azolla ZS 208L
208 ltr

110474

SPECIFICATIONS

International specifications

OEM

- AFNOR NF E 48-603 HM
- ISO 6743/4 HM
- DIN 51524 P2 HLP
- CINCINNATI MILACRON P68, P69, P70
- VICKERS M-2950S, -I-286
- DENISON HF0, HF1, HF2 (T6H20C)



Glussi

L-HM 32

Heiti

Vörunúmer



Glussi 32 Lotos L-HM 20L
20 ltr

20033

Glussi 32 Lotos L-HM 205L
205 ltr

20032

Specifications, classifications:

ISO VG 15-150

ISO-L-HM,

DIN HLP (DIN 51524cz2),

Dresta K-34, K-35 produced by HSW.



Glussi

32

Heiti

Vörunúmer



Glussi 32 Total Visga
20 ltr

145426

Glussi 32 Total Visga
208 ltr

174884

Auxiliary Mineral Lubricants

Approvals

These oils meet the specifications of the world's leading hydraulic equipment manufacturers NF E 48603 class HV, DIN 51 524 part 3 class HVL, ISO 6743/4 class HV.





Glussi

32



Heiti Vörunúmer

Glussi 32 Total Cirkan RO 112515
20 ltr

Hentar fyrir tæki sem vinna undir miklu hitaálagi.

SPECIFICATIONS

International specifications

Manufacturers

- ISO 6743/4 Category HL
- ISO 6743/6 Category CKB
- ISO 11158 Category HL
- ISO 12925-1 Category CKB



Glussi fyrir matvælaíðnaðinn

32



Heiti Vörunúmer

Glussi 32 Nevastane AW matvælav. 190503
20 ltr Matvælavottaður



SPECIFICATIONS

- The formulation of **NEVASTANE AW** oils complies with the FDA chapter 21 CFR, 178.3570.
- **NEVASTANE AW** oils are **NSF H1** registered:
NEVASTANE AW 22: No 146880 NEVASTANE AW 32: No 146881
NEVASTANE AW 46: No 146882 NEVASTANE AW 68: No 146883
- **NEVASTANE AW** oils are **Kosher, Halal** and **ISO 21469** certified.
- International specification: ISO 6743-4 HM.



Glussi lyktarlaus

32



Heiti Vörunúmer

Glussi 32 Total Equivis ZS lyktarlaus 110571
20 ltr

Þolir hitastig frá -30°C. upp í 100°C
Lyktarlaus glussi sem hentar vel fyrir lyftur í húsum.

SPECIFICATIONS

International specifications.

- AFNOR NF E 48-603 HV
- VICKERS I-286-S, M-2950-S
- ISO 6743/4 CATEGORY HV
- CINCINNATI MILACRON P68, P69, P70
- DIN 51524 PART 3 CATEGORY HVLP



GLUSSI

HLP-46

HEITI

VÖRUNÚMER



GLUSSI VAL HLP 46 20 LTR
GLUSSI VAL HLP46 208 LTR

044 878270
044 854004

Performance levels
DIN 51524 (part 2)



Glussi

46

Heiti

Vörunúmer



Glussi 46 Total Azolla ZS 20L
20 ltr
Glussi 46 Total Azolla ZS 208L
208 ltr

110478
110477

SPECIFICATIONS

International specifications

OEM

- AFNOR NF E 48-603 HM
- ISO 6743/4 HM
- DIN 51524 P2 HLP
- CINCINNATI MILACRON P68, P69, P70
- VICKERS M-2950S, -I-286
- DENISON HF0, HF1, HF2 (T6H20C)



Glussi

L-HM 46

Heiti

Vörunúmer



Glussi 46 Lotos L-HM 20L
20 ltr
Glussi 46 Lotos L-HM 205L
205 ltr

20047
20046

Specifications, classifications:

ISO VG 15-150

ISO-L-HM,

DIN HLP (DIN 51524cz2),

Dresta K-34, K-35 produced by HSW.



Glussi

46



Heiti

Vörunúmer

Glussi 46 Total Visga
20 ltr

145174

Glussi 46 Total Visga
208 ltr

174886

Auxiliary Mineral Lubricants

Approvals

These oils meet the specifications of the world's leading hydraulic equipment manufacturers NF E 48603 class HV, DIN 51 524 part 3 class HVL, ISO 6743/4 class HV.



Glussi

46



Heiti

Vörunúmer

Glussi 46 Total Cirkan RO
208 ltr

112516

Hentar fyrir tæki sem vinna undir miklu hitaálagi.

SPECIFICATIONS

International specifications

- ISO 6743/4 Category HL
- ISO 6743/6 Category CKB
- ISO 11158 Category HL
- ISO 12925-1 Category CKB

Manufacturers



Glussi fyrir matvælaíðnaðinn

46



Heiti

Vörunúmer

Glussi 46 Nevastane SH matvælav.
20 ltr Matvælavottaður NSF H1

190486



Food industry

SPECIFICATIONS

- The formulation of NEVASTANE SH oils complies with the FDA chapter 21 CFR, 178.3570.
- NEVASTANE SH oils are NSF H1 registered:
NEVASTANE SH 32: No 147292
NEVASTANE SH 68: No 147294
NEVASTANE SH 46: No 147293
NEVASTANE SH 100: No 147295
- NEVASTANE SH oils are Kosher, Halal and ISO 21469 certified.
- International specification: ISO 6743-4 HV, DIN 51506 VD-L, ISO 6743-3 DAJ.



Glussi lyktarlaus

46



Heiti

Vörunúmer

Glussi 46 Total Equivis ZS lyktarlaus
20 ltr

110574

Glussi 46 Total Equivis ZS lyktarlaus
208 ltr

110573

þolir hitastig frá -30°C. upp í 100°C
Lyktarlaus glussi sem hentar vel fyrir lyftur í húsum.

SPECIFICATIONS

International specifications.

- AFNOR NF E 48-603 HV
- VICKERS I-286-S, M-2950-S
- ISO 6743/4 CATEGORY HV
- CINCINNATI MILACRON P68, P69, P70
- DIN 51524 PART 3 CATEGORY HVLP



Glussi

46



Compressor



Heiti

Vörunúmer

Glussi 46 Total Dacnis SH
20 ltr

112591

Skrúfupressuolía og loftpressur

SPECIFICATIONS

International specifications

- ISO 6743 classified DAJ for heavy duty applications.



Glussi Eldþolinn

46



Heiti

Vörunúmer

Glussi 46 Total Hydransafe HFUD
205 ltr

156782

Eldþolinn glussi.



SPECIFICATIONS

International specifications

Approval

- ISO 6743/4 HFUDU
- ISO 12922
- FACTORY MUTUAL in accordance with FM Approval Standard 6930 - "Flammability classification of Industrial Fluids".



Tjakkoolía

HEITI

VÖRUNÚMER



TJAKKAOLÍA 500ML

066 HJO/500ML

Hydraulic oil recommended for use in all jacks (trolley and bottle) and cranes.

N.B. Never use brake fluid to top up a hydraulic unit.

LOTOS Oil Glussi

68



Heiti	Vörunúmer
Glussi 68 Lotos L-HM 205 ltr 205ltr	20068

Specifications, classifications:

ISO VG 15-150
ISO-L-HM,
DIN HLP (DIN 51524cz2),
Dresta K-34, K-35 produced by HSW.

TOTAL Lubmarine Glussi

68



Heiti	Vörunúmer
Glussi 68 Total Visga 20 ltr	145230
Glussi 68 Total Visga 208 ltr	174888

Auxiliary Mineral Lubricants

Approvals

These oils meet the specifications of the world's leading hydraulic equipment manufacturers NF E 48603 class HV, DIN 51 524 part 3 class HVL, ISO 6743/4 class HV.

TOTAL Glussi

68



Heiti	Vörunúmer
Glussi 68 Total Cirkan RO 20 ltr	112519

Hentar fyrir tæki sem vinna undir miklu hitaálagi.

SPECIFICATIONS

International specifications

Manufacturers

- ISO 6743/4 Category HL
- ISO 6743/6 Category CKB
- ISO 11158 Category HL
- ISO 12925-1 Category CKB



Glussi fyrir matvælaíðnaðinn

68



Heiti	Vörunúmer
-------	-----------

Glussi 68 Nevastane AW matvælav. 20 ltr Matvælavottaður NSF H1	190550
---	--------

Glussi 68 Nevastane AW matvælav. 208 ltr Matvælavottaður NSF H1	190551
--	--------



SPECIFICATIONS

- The formulation of **NEVASTANE AW** oils complies with the FDA chapter 21 CFR, 178.3570.
- **NEVASTANE AW** oils are **NSF H1** registered:
NEVASTANE AW 22: No 146880 NEVASTANE AW 32: No 146881
NEVASTANE AW 46: No 146882 NEVASTANE AW 68: No 146883
- **NEVASTANE AW** oils are **Kosher, Halal** and **ISO 21469** certified.
- International specification: ISO 6743-4 HM.



Glussi lyktarlaus

68



Heiti	Vörunúmer
-------	-----------

Glussi 68 Total Equivis ZS lyktarlaus 20 ltr	110577
---	--------

Glussi 68 Total Equivis ZS lyktarlaus 208 ltr	110576
--	--------

Polir hitastig frá -30°C. upp í 100°C
Lyktarlaus glussi sem hentar vel fyrir lyftur í húsum.

SPECIFICATIONS

International specifications.

- AFNOR NF E 48-603 HV
- VICKERS I-286-S, M-2950-S
- ISO 6743/4 CATEGORY HV
- CINCINNATI MILACRON P68, P69, P70
- DIN 51524 PART 3 CATEGORY HVLP



Glussi

68



Compressor



Heiti	Vörunúmer
-------	-----------

Glussi 68 Total Dacnis SH 20 ltr	162122
-------------------------------------	--------

Skrúfupressuolía og loftpressur

SPECIFICATIONS

International specifications

- ISO 6743 classified DAJ for heavy duty applications.



Glussi Eldþolinn

68



Heiti

Vörunúmer

Glussi 68 Total Hydransafe HFDU LC
208 ltr

112456

Eldþolinn glussi.



SPECIFICATIONS

International specifications

Approval

- ISO 6743/4 HFDU
- ISO 12922
- FACTORY MUTUAL in accordance with FM Approval Standard 6930 - "Flammability classification of Industrial Fluids".



Glussi

100



Compressor



Heiti

Vörunúmer

Glussi 100 Total Dacnis SH
20 ltr

112593

Skrúfupressuolía og loftpressur

SPECIFICATIONS

International specifications

- ISO 6743 classified DAJ for heavy duty applications.



Glussi

100



Heiti

Vörunúmer

Glussi 100 Total Equivis ZS lyktarlaus
20 ltr

119494

Polir hitastig frá -30°C. upp í 100°C

Lyktarlaus glussi sem hentar vel fyrir lyftur í húsum.

SPECIFICATIONS

International specifications.

- AFNOR NF E 48-603 HV
- VICKERS I-286-S, M-2950-S
- ISO 6743/4 CATEGORY HV
- CINCINNATI MILACRON P68, P69, P70
- DIN 51524 PART 3 CATEGORY HVLP



Glussi

150



Heiti

Vörunúmer

Glussi 150 Total Cirkan RO
208 ltr

112522

Hentar fyrir tæki sem vinna undir miklu hitaálagi.

SPECIFICATIONS

International specifications

Manufacturers

- ISO 6743/4 Category HL
- ISO 6743/6 Category CKB
- ISO 11158 Category HL
- ISO 12925-1 Category CKB



Glussi

460



Heiti

Vörunúmer

Glussi 460 Total Cirkan RO
208 ltr

112542

Hentar fyrir tæki sem vinna undir miklu hitaálagi.

SPECIFICATIONS

International specifications

- ISO 6743/4 Category HL
- ISO 6743/6 Category CKB
- ISO 11158 Category HL
- ISO 12925-1 Category CKB

Manufacturers



Glussi

460



Heiti

Vörunúmer

Glussi 460 Nevastane XSH matvælav.
20 ltr Matvælavottaður

190639

- NEVASTANE XSH opfylder kravene i FDA kapitel 21 CFR, 178.3570
- NEVASTANE XSH er NSF H1 registrerede
- NEVASTANE XSH er Kosher, Halal og ISO 21469 certificerede
- Internationale specifikationer: ISO 12925-1 CKD
- DIN 51517-3 CLP
- DIN 51354-2 – FZG A/8, 3/90°C – Fail stage >12
- ASTM D 4172 – 4 ball test – wear (Scar diameter) – 0,3 mm.



Food industry



Glussi - Sleðaolía

MS2 og MS220



Heiti

Vörunúmer

Glussi Drosera MS 2
208 ltr

176747

Glussi Drosera MS 220 sleðaolía 20 L
20 ltr

112587

APPLICATIONS

DROSERAS MS



Machine tools

DROSERAS MS offers a wide range of products for all parts of machine tools (hydraulics, slides, gears).

- Machine tool slide ways under all conditions of speed and load (grades 68 to 320).
- Hydraulic circuits for hydraulic pumps and motors (grades 32 and 46).
- Gear boxes and feed mechanisms of all types with or without wet electro magnetic clutches (grades 68 to 320).
- High speed machine spindles (grades 5, 10, 15 and 22) and very high speed (grade 2).
- Hydrodynamic lubrication of mill roll stands during grinding (VG 460).
- Particularly suitable for centralized lubrication systems.
- ISO VG 68 to 150 are also well suited to cold heading applications.

SPECIFICATIONS

- ISO 6743/2 : FD2 ; FD5 ; FD10 ; FD 22 ; FD 32
- ISO 6743/4 : HG32
- ISO 6743/13 : GA68 ; GA100 ; GA150 ; GA220
- DIN 51502 : CGLP46 ; CGLP68 ; CGLP100 ; CGLP150 ; CGLP220 ; CGLP320 ; CGLP 460
- Drosera MS range is homologated by 40+ OEMs



Glussi



Heiti

Vörunúmer

Glussi Hitachi 5000
208 ltr

197841



Demparaolía (Citroen LDS)



HEITI

VÖRUNÚMER

Total Fluide LDS Syn. glussi á Citroen
1 Ltr
Demparaglussi á Citroen sýnþetiskur

213758

APPLICATIONS

- Synthetic fluid of **orange** colour for the hydraulic system of Citroën cars equipped with "HYDRActive 3".
Do not use when a mineral fluid of **fluo green** colour is requested (LMH Plus)

CUSTOMER BENEFITS

- Super multigrade fluid
- Exceptionally high viscosity index
- Very low pour point.
- Very high thermal stability
- Very good protection against wear and corrosion
- Excellent lubricating properties
- Contributes to improve comfort

SPECIFICATIONS

PSA S71 2710



Demparaolía (Citroen LHM)



HEITI

VÖRUNÚMER

Glussi Citroen LHM 1 ltr

214174

LHM Plus er míneralskur glussi sem er mikið notaður á glussakerfi Citroen. Einnig er LHM Plus notaður á bremsukerfi Ami 8, Ami Super, Dyane og Mehari síðan september 1977 og 2Cv síðan í júlí 1982.



Loftpressuolía - Loftverkfæraolía



HEITI

VÖRUNÚMER

Loftpressuolía 1 Líter
Fyrir stimpilpressur- Compressor oil
ISO68/SAE20W

066 CPO1S

Olia fyrir loftvekfæri 500ml
Air tool oil

066 ATO500S



Mótorhjólalía

2T



HEITI

VÖRUNÚMER

Semi synthetic

MÓTORHJ.OLÍA 2T DURABLEND 1 Ltr

044 862010

MÓTORHJ.OLÍA 2T DURABLEND 60 Ltr

044 14117

Performance levels

API: TC

JASO: FD

ISO: L-EGD



Mótorhjólalía

2T



HEITI

VÖRUNÚMER

Synthetic Based

ELF Moto 2 Off Road tvígengisolía

213942

1 ltr

- INTERNATIONAL STANDARDS

✓ API TC

✓ JASO FD

✓ ISO L-EGD



Mótorhjólalía

2T



HEITI

VÖRUNÚMER

100% Synthetic

ELF Moto 2 Tech tvígengisolía

213951

- INTERNATIONAL STANDARDS

✓ API TC

✓ JASO FD

✓ ISO L-EGD



Mótorhjólalía

4T 10W/40



HEITI

VÖRUNÚMER

Semi synthetic

MÓTORHJ.OLÍA 4T DURABLEND 1 Ltr

044 862061

MÓTORHJ.OLÍA 4T DURABLEND 4 Ltr

044 14207

Performance levels

API: SL

JASO MA

JASO MA2



Mótorhjólalía

4T 10W/40 SAE



HEITI

VÖRUNÚMER

Synthetic Based

ELF Moto 4 Road 10W-40 1 ltr

213957

ELF Moto 4 Road 10W-40 4 ltr

213958

- INTERNATIONAL STANDARDS

✓ API SN

✓ JASO MA2



Mótorhjólalía

4T 10W/50



HEITI

VÖRUNÚMER

Full synthetic

MÓTORHJ.OLÍA 4T SYN 10W/50 1 Ltr

044 862067

Performance levels

API: SN

JASO MA

JASO MA2



Mótorhjólalía

4T 10W/50 SAE



HEITI

VÖRUNÚMER

Synthetic Technology

ELF Moto 4 Tech 10W-50 synþetísk

213950

4 ltr

• INTERNATIONAL STANDARDS

✓ API SN

✓ JASO MA2



Mótorhjólalía

4T 10W/60 SAE



HEITI

VÖRUNÚMER

100% Synthetic

ELF Moto 4 Race 10W-60 1 ltr

213947

ELF Moto 4 Race 10W-60 4 ltr

213948

• INTERNATIONAL STANDARDS

✓ API SN

✓ JASO MA2



Mótorhjólalía

4T 20W/50 SAE



HEITI

VÖRUNÚMER

Mineral Base

ELF Moto 4 Cruise 20W-50 mînerölsk

213953

4 ltr

• INTERNATIONAL STANDARDS

✓ API SH

✓ JASO MA2



Mótorhjólalía

4T 20W/50



HEITI

VÖRUNÚMER

Semi synthetic

MÓTORHJ.OLÍA 4T 20W/50 1 Ltr

044 862063

Performance levels

API: SL

JASO MA

JASO MA2



Mótorhjóra-gírolía

80W/90



HEITI

VÖRUNÚMÉR

ELF Moto Gear Oil gírolía 80W-90
1 ltr

213962

PERFORMANCES

- Selected mineral compounds
- Grade
- API GL5
- MOTO GEAR OIL 80W-90 is a lubricant using selected mineral compounds.
- SAE grade: 80W-90 recommended by the major 4-stroke motorcycle constructors.
- MOTO GEAR OIL 80W-90 meets the most stringent requirements of the international API standard as required by the 4-stroke motorcycle constructors.



Demparaolía á mótorhjól

2,5W - 5W - 10W



HEITI

VÖRUNÚMÉR

Synthetics

ELF Moto Fork Oil 2,5W sýnþetísk
500ml
ELF Moto Fork Oil 5W sýnþetísk
500ml
ELF Moto Fork Oil 10W sýnþetísk
500ml

213968

213967

213966

PERFORMANCES

- Synthetics
- SAE 2,5 - 5 et 10W
- The basic oils for forks and shock absorbers are 100% synthetic
- To obtain an SAE 7.5W grade, 5W and 10W grades may be mixed in a proportion of 50/50.



Demparaolía á mótorhjól

10W - 15W - 20W



HEITI

VÖRUNÚMÉR

Mineral oils

ELF Moto Fork Oil 15W hálf-sýnþetísk
500ml
ELF Moto Fork Oil 20W hálf-sýnþetísk
500ml

213964

194971

PERFORMANCES

- Mineral oils
- SAE 10 - 15 et 20W
- Selected "hydraulic quality" mineral oil based formulae.
- Wide viscosity range suitable for all applications.



Lofthfiltersolía



HEITI

VÖRUNÚMÉR

AIRFILTER OIL 1 Ltr
Lofthreinsaraolía fyrir loftsíur

044 0885

AIR FILTER CLEANER 5 LTR
Hreinsiefni fyrir loftsíur

044 0886



Mótorhjólaefnavara

Sjá nánar á www.kemi.is



HEITI

VÖRUNÚMÉR

ELF Moto Chain Lube keðjufesti
400ml Smursprey 195628

ELF Moto Chain Paste keðjufesti
250ml Keðju paste 201304

ELF Moto Degreaser sprej (fituleysir)
400ml 199795

ELF Moto Multilube+ smursprey
400ml 199796



Slátturvélaolía



HEITI

VÖRUNÚMER

Slátturvélaolía SAE30 1ltr
Valvoline

044 15960

Smurolía 30W einþ. SAE 30 1 ltr
Lotos Green

20081

Smurolía 30W einþ. SAE 30 205 ltr
Lotos Green

20080



HEITI

VÖRUNÚMER

LAWN-BOY 2 CYCLE OIL 8oz

102 LB2C



Utanborðsmótors olía



HEITI

VÖRUNÚMER

Utanborðsmótor-olía Super 2T 4L

044 16027



Utanborðsmótors olía



HEITI

VÖRUNÚMER

Tvígengisolía á utanborðsmótora
1 ltr Neptuna

213761



SPECIFICATIONS AND APPROVALS

International Specifications:

API TC
NMMA TC-W3®

Suitable for:

- ✓ JOHNSON
- ✓ MARINER
- ✓ MERCURY
- ✓ SUZUKI
- ✓ YAMAHA





Frostlögur
Blandast við marga aðra liti.



HEITI

VÖRUNÚMER

Glær á litinn

FROSTLÖGUR MULTI VEHICLE 1 Ltr	044 874738
FROSTLÖGUR MULTI VEHICLE 5 Ltr	044 874739
FROSTLÖGUR MULTI VEHICLE 20 Ltr	044 874762
FROSTLÖGUR MULTI VEHICLE 208LTR	044 874740

Multi-Vehicle Coolant Concentrate

Concentrate mixed with (demineralized) water	Freezing Point °C
33% concentrate	-20
40% concentrate	-25
50% concentrate	-37

Multi-Vehicle Coolant Concentrate

Afnor 15-601, 1991
ASTM D3306 (D4656)
SAE J1034, J814, J1941
BMW N600.69.0
BS 6580, 1992
Citroen (PSA B71 5110)
CUNA NC956-16
Ford WSS-M97B44-D
GM B 040 0240
Honda type 2
Isuzu
Jaguar/Land Rover: STJLR.651.5003
MB-325.0, 2, 3, 5, 6

Multi-Vehicle Coolant Concentrate

Nissan
O-Norm V5123
Opel 6277M (B 040 1065)
Peugeot (PSA B71 5110)
Renault Glaceol AL type C; RX type D
Saab (6901 599)
Toyota TSK 2601G-8A
Volvo
Recommended by Valvoline for:
VW TL 774 C, D, F, G, J
VW G11, G12, G12+, G12++ and G13 applications
Audi, Seat, Skoda



Frostlögur



HEITI

VÖRUNÚMER

Grænn á litinn

FROSTLÖGUR HT-12 GREEN 1 LTR	044 889279
FROSTLÖGUR HT-12 GREEN 5 LTR	044 896129
BMW LC-18 BMW LC-87	

HEITI

VÖRUNÚMER

Bleikur á litinn

FROSTLÖGUR HT-12 PINK 1 LTR	044 889278
FROSTLÖGUR HT-12 PINK 5 LTR	044 896128
VW TL 774-L (G12EVO) VW TL 774-C/D/F/G/J	

Performance levels

ASTM D3306
ASTM D4985
ASTM D6210
AS 2108-2004
BS 6580:2010

Performance levels

Cummins CES 14603, CES 14439
CUNA NC 956-16
Deutz DQC CC-14
GB 29743-2013
JIS K 2234:2006
ONORM V 5123
PN-C40007:2000
SANS 1251:2005



Frostlögur



HEITI

Frostlögur OEM Advanced 40 5 Ltr
Bléikur á litinn

VÖRUNÚMER

044 892091



GLYSANTIN® G40® by BASF is approved by:
Cummins CES 14603
Deutz DQC CC-14
Irizar (from 2016)
Liebherr Minimum LH-01-COL3A
MB-Approval 325.5 and 325.6
MAN 324 Type Si-OAT
MTU MTL 5048
Porsche From MY 2010
Smart (MB-Approval 326.0)
TL 774-G (G12++): VW / Audi / Seat / Skoda / Lamborghini / Bentley / Bugatti

Performance levels
AS 2108-2004
ASTM D 3306
ASTM D 4985
BS 6580:2010
China GB 29743-2013
CUNA NC 956-16
JIS K 2234:2006
ONORM V 5123
SAE J1034
SANS 1251:2005



Frostlögur



HEITI

Frostlögur OEM Advances 48 1 ltr
Blá-grænn á litinn
Frostlögur OEM Advances 48 5 ltr
Blá-grænn á litinn

VÖRUNÚMER

044 892095

044 892096



OEM Approvals
BMW LC-87
Deutz DQC CA-14
MAN 324 Type NF
MB-Approval 325.0
MB-Approval 326.0
MTU MTL 5048
Performance levels
Detroit Diesel 7SE298
TL 774-C: VW / Audi / Seat / Skoda
Federal Specification A-A-870A
Jaguar
Jenbacher TA-Nr. 1000-0201
Liebherr Minimum LH-00-COL3A
MAN Diesel & Turbo Liste 3.3.7
Maybach/Smart MB 325.0/326.0 (until 2014)

Performance levels
MB Passenger cars (until April 2014)
MB Trucks (until September 2011)
Opel/Vauxhall (until 2000) B 040 0240
Porsche (until 1995)
Rolls-Royce (from 1998)
Saab 690 1599
Tesla (from 2013)
TMC of ATA RP-302B
Van Hool
Volvo 2015 (cars) and older
Volvo Truck (until 2005)
Zastava
ASTM D3306 / D4985
GM1899M / 1825M
SAE J814 / J1034 / J1941



Frostlögur



HEITI

VÖRUNÚMER

Frostlögur Peak Global Lifetime
3,78 ltr

0203500155

RECOMMENDED FOR USE WHERE THE FOLLOWING SPECIFICATIONS ARE CITED*:

- Chrysler MS-7170
- Chrysler MS-9769
- Chrysler MS-12106
- Ford ESE M97B44-A
- Ford W55-M97B44-D
- Ford W55-M97B51-A1
- Ford W55-M97B57-A1
- GM 1825M
- GMW3420

MEETS OR EXCEEDS THE FOLLOWING SPECIFICATIONS:

- ASTM D3306
- ASTM D4985
- ASTM D6210

FREEZE/BOIL PROTECTION CHART

Coolant/Water Ratio*	PROTECTION FROM	
	Freezing Down to	Boiling Up to*
50/50	-34°F (-36°C)	265°F (129°C)
60/40	-62°F (-52°C)	270°F (132°C)
70/30	-84°F (-64°C)	276°F (135°C)



Frostlögur



HEITI

VÖRUNÚMER

Frostlögur bleikur Glacelf Auto Supra
1 ltr

213781

Frostlögur bleikur Glacelf Auto Supra
5 ltr

206467

Frostlögur bleikur Glacelf Auto Supra
20 ltr

148023

Frostlögur bleikur Glacelf Auto Supra
208 ltr

148022

% volume of GLACELF AUTOSUPRA	33	40	50
Freezing Point, °C (temperature at which first crystals appear)	-20	-26	-37
Boiling Point, °C	105	107	110

SPECIFICATIONS

GLACELF AUTO SUPRA meets the *international specifications* for antifreezes:

- AFNOR NFR15-601
- ASTM D3306
- ASTM D4656
- ASTM D4985
- ASTM D6210
- BS 6580
- JIS K2234
- SAE J1034
- NATO S-759

GLACELF AUTO SUPRA is based on a *technology officially approved* by the following manufacturers:

- VW SEAT AUDI SKODA PORSCHE: VW TL 774 D / F (G12/G12+)
- DAIMLER MB 325.3
- FORD W55-M97B44-D
- MAZDA MEZ MN 121D
- JAGUAR STJLR 651.5003
- MAN 324 Typ SNF
- DEUTZ DQCCB-14
- DAF 74002
- GMW 3420
- JENBACHER TA 1000-0200
- MWM 0199-99-2091/12
- WARTSILA 32-9011
- CUMMINS IS series u N14
- CUMMINS CES 14439
- LIEBHERR MD1-36-130
- MTU MTL 5048
- VALTRA
- SAAB B 040 1065
- LEYLAND TRUCKS DW03245403

GLACELF AUTO SUPRA *meets the requirements* of:

- RENAULT RNUR 41-01-001/-S Type D
- CASE NEW HOLLAND MAT 3624
- FENDT
- KOMATSU 07.892 (2009)
- CUMMINS CES14603
- ASTON MARTIN
- FIAT 9,55523
- CLAAS
- JOHN DEERE JDM H5



Mótorhjóra frostlögur



HEITI

VÖRUNÚMER

ELF Moto Coolant Organic frostlögur
1 ltr Grænn á litinn

213973

"Very long-life" coolant.

PERFORMANCES

- AFNOR NFR 15-601
- ASTM D3306
- BS 6580

ELF MOTO COOLANT ORGANIC meets the requirements of the main international standards for coolants.



Frostlögur fyrir húsbíla



HEITI

VÖRUNÚMER

Frostlögur fyrir húsbíla blandaður
5 ltr Monopropylene glycol - blár

112685-RV



Frostlögurinn er tilbúinn til notkunar, ætlaður á neysluvatns- sem og önnur lagnakerfi húsbíla og ferðavagna. Inniheldur öfluga bakteríu- og tæringarvörn. Frostþol allt að -26°C



Frostlögur Matvælavottaður



HEITI

VÖRUNÚMER

Frostlögur Nevastane matvælavottaður
5 ltr

168333-05

Frostlögur Nevastane matvælavottaður
20 ltr

168333-20

Frostlögur Nevastane matvælavottaður
205 ltr

168333



Food Industry

APPLICATIONS

- NEVASTANE ANTIFREEZE, when mixed with water, is a coolant specially designed for cooling circuits in the food industry: drinks, ice creams and frozen food processing.
- NEVASTANE ANTIFREEZE should be diluted with clear water before use.
- The dilution is determined by the cooling system requirements. However, to ensure good corrosion protection, it is recommended to use at least 30 vol.% of NEVASTANE ANTIFREEZE in the coolant solution.

Dilution NEVASTANE ANTIFREEZE, vol %	31,6	37,3	42,0	46,0	49,3	52,2
Freezing point of the coolant, °C	-15	-20	-25	-30	-35	-40

Method: ASTM D1177 - Above characteristics are mean values given as an information.

SPECIFICATIONS

- NEVASTANE ANTIFREEZE, mixed with the appropriate amount of water, is a coolant based on mono propylene glycol and additives complying with FDA, 21 CFR, 178.3570.
- NEVASTANE ANTIFREEZE is NSF HT1 registered No 139291



Frostlögur



HEITI

VÖRUNÚMER

Frostlögur bleikur Glacelf G13
20 ltr

188328-20

Frostlögur bleikur Glacelf G13
208 ltr

188328

APPLICATION

Dilution in demineralised or softened water

Minimum 33%

CUSTOMER BENEFITS

Long-term protection

Metals protection

GLACELF G13, diluted in demineralised water (<8°F) becomes a permanent coolant that can be used throughout the year.

It is essential to **mix mechanically** the antifreeze with water to obtain a coolant perfectly mixed.

Protection against freezing depends of proportions of **GLACELF G13** in water

% volume of GLACELF G13	36.6	45.8	53
Freezing point, °C (ASTM D1177)	-20°C	-30°C	-40°C

These are mean values provided for indicative purposes only

It is recommended to use at least **33% of GLACELF G13** in the final solution. **Do not use in proportions above 33%.**

GLACELF G13 may be used with confidence in engines manufactured from cast iron, aluminum or combinations of the two metals, and in cooling systems made of aluminum or copper alloys.

GLACELF G13 meets the requirements of VWTL774J (G13) and has successfully passed all stringent VW lab, fleet and performance test. To ensure a good corrosion protection, it is recommended to use at least 33% vol. % of **GLACELF G13** in the coolant solution.

Long life protection against all types of corrosion thanks to a particular combination of organic inhibitors.

Long-term stability as a result of high performance silicate stabilizer which prevents gel-formation.

High-performance additives used allow to protect all metals including aluminum and ferrous alloys.

Environmentally friendly due to the absence of borate, nitrite, amines and phosphates.



Frostlögur



HEITI

VÖRUNÚMER

Frostlögur bleikur Frizantin G12+ 20L
20 Ltr

1340420

Adeco Frizantin Concentrate

ADECO FRIZANTIN G12+	50%
Water Dilution	1 : 1
Freezing Point	- 38 °C

SRPS H.Z2.010 Tip 1; ASTM D3306/4985 Tip 1; SAE J 1034; BS 6580; AFNOR NF R15-601; VW/Audi/Seat/Škoda/Porsche TL 774-D/F (G12/G12+); Ford WSS M97B44-D/E; MB 325.3; MAN 324 Type SNF.

SEALEY

Frostlögsmælar og fl.



HEITI

VÖRUNÚMER

FROSTLÖGSMÆLIR F/ETHYLENE

066 AK4120

FROSTLÖGSMÆLIR F/ PROPYLENE

066 AK4122

FROSTLÖGSMÆLIR ETHELYN GLYCOL
BLÁR

066 VS4120

FROSTLÖGSMÆLIR PROPYLEN GLYCOL
GRÆNN

066 VS4121

MÆLIR F/ FROSTLÖG, SÝRU, AdBlu

066 VS0052

Vatnskassahreinsibysa
Coolant Flush Jet Wash Gun

066 VS0050



Bremsuvökvi - Fólksbílar - Vörubílar - Fleiri

DOT 4

Heiti

Vörunúmer



Bremsuvökvi DOT4/ 0,5 Ltr

090 MBF4-0500B

Bremsuvökvi DOT 4. 1 Ltr

090 MBF4-1000B

Bremsuvökvi DOT 4. 20 Ltr

090 MBF4-20

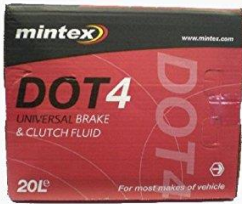

Specification	Part No.	Boiling point	Wet boiling point	Information	Unit	GHS Icon
DOT 4	MBF4-0250B	~ 270° C	~ 163° C	SAE J 1704, ISO 4925 (Class 4), FMVSS 116 DOT 4	250 ml bottle	
DOT 4	MBF4-0500B	~ 270° C	~ 163° C	SAE J 1704, ISO 4925 (Class 4), FMVSS 116 DOT 4	500 ml bottle	
DOT 4	MBF4-1000B	~ 270° C	~ 163° C	SAE J 1704, ISO 4925 (Class 4), FMVSS 116 DOT 4	1 l bottle	
DOT 4	MBF4-5000B	~ 270° C	~ 163° C	SAE J 1704, ISO 4925 (Class 4), FMVSS 116 DOT 4	5 l can	
DOT 4	MBF4-20000	~ 270° C	~ 163° C	SAE J 1704, ISO 4925 (Class 4), FMVSS 116 DOT 4	20 l can	



BOSCH Bremsuvökvi - Fólksbílar - Vörubílar og fleiri

DOT 4

Heiti

Vörunúmer



Bremsuvökvi DOT 4 - Bosch 1L

1987479107

Bremsuvökvi DOT 4 - Bosch 5L

1987479108

Bosch DOT 4 brake fluid

- Suitable for all hydraulic braking systems
- Mixable with all brake fluids complying with FMVSS § 571.116 DOT 4, SAE J 1704 or ISO 4925 unless the vehicle manufacturer specified otherwise

DOT 4	Bosch
Dry boiling point (°C)	≥230
Wet boiling point (°C)	≥155
Viscosity at -40 °C (mm ² /sec)	1800



Bremsuvökvi - Fólksbílar og fleira

DOT 4

Heiti

Vörunúmer



Bremsuvökvi DOT 4 ELF Frelub 650 1L

213868

PERFORMANCES

INTERNATIONAL SPECIFICATIONS

- Exceeds the latest requirements of the following international standards:
SAE J 1704
FMVSS 116 (DOT 4)
Frelub 650 is approved by Renault



Bremsuvökvi - Fólksbílar og fleira

DOT 4



Heiti

Vörunúmer

Bremsuvökvi DOT 4 - K2 250ml
250ml

T124



BOSCH Bremsuvökvi - Fólksbílar og fleira

DOT 4 ENV4



Heiti

Vörunúmer

Bremsuvökvi ENV4 - Bosch 1L
1 ltr

1987479202

Bosch ENV4 er bremsuvökvi sem er sérstaklega ætlaður á ABS og ESP bremsukerfi þar sem slíkir kerfi eru snarpari en hefðbundin bremsukerfi sökum tölvubúnaðar. EBV stendur fyrir "Envelope" og þýðir í raun að ENV4 vökvann má nota á öll bremsukerfi sem notast við hefðbundin DOT4 bremsuvökva. Uppfyllir eftirfarandi staðla : ISO 4925 (CLASS 6)



Bremsuvökvi - Fólksbílar og fleira

DOT 4 HBF4 OEM



Heiti

Vörunúmer

Bremsuvökvi HBF4 OEM+ Total 1L
1 ltr

214188

PERFORMANCES

Meets the requirements of the following international standards:

- SAE J 1703/ 04
- FMVSS 116 DOT 4
- ISO 4925 Class4



Bremsuvökvi - Fólksbílar - Vörubílar

DOT 5



Heiti

Vörunúmer

Bremsuvökvi DOT-5. 1-LTR.
1 ltr

090 MBF5-1000



Bremsuvökvi - Mótorhjól

DOT 5,1



HEITI

VÖRUNÚMÉR

ELF Moto bremsuvökvi DOT 5.1
500 ml Synþetískur

213969

USE

Motorcycle application

- Particularly suitable for braking systems operating under very harsh conditions, particularly on motorcycles fitted with disc brakes and used for competition. This synthetic fluid is miscible with all other chemical synthetic fluids of the DOT 3, DOT 4 and DOT 5.1 type with the exception of silicon DOT 5 fluids and all the fluids with a mineral basis (special LHM fluids and others).

PERFORMANCES

FMVSS 116 DOT 5.1

- This fluid meets the requirements of standard FMVSS DOT 5.1 (DOT 5 silicon-free)



Smurfeiti



Smurfeiti fyrir bremsuhluti.

Heiti	Vörunúmer
Smurefni 75ml "Metal Free"	090 CERATEC



Smurfeiti fyrir bremsuhluti.



Heiti	Vörunúmer
Bremsufeiti K2 Cera High-Temp Fjölnota feiti , leiðir ekki	B408
Bremsufeiti K2 Synthetic Grease Fjölnota feiti, leiðir ekki	B405
Bremsuhreinsir spray K2 600ml 12 Stk í kassa.	W105



Bremsuvökvamælir



Heiti	Vörunúmer
Bremsuvökvamælir Led Mælir raka í Dot 3, 4 & 5 vökva	066 VS027
Bremsuvökvamælir penni Mælir raka í öllum vökvum.	066 VS0274



Heiti	Vörunúmer
BREMSUVÖKVA KÚTUR 2,5LTR	066 VS820
BREMSUVÖKVA ÁFYLLINGARKÚTUR	066 VS821
Model No:	VS821
Maximum Pressure:	30psi
Capacity:	1.5ltr
Adaptor(s):	Ø45mm Cap

Rúðuvökvi Blandaður



HEITI	VÖRUNÚMER
Rúðuvökvi frostþol -26°C 5Ltr Kemi rúðuvökvi	020-00110
Rúðuvökvi frostþol -18°C 5Ltr Kemi rúðuvökvi	020-00107
Rúðuvökvi frostþol -18°C 20 Ltr Kemi rúðuvökvi	020-00105
Rúðuvökvi frostþol -18°C 200 Ltr Kemi rúðuvökvi	020-00108

Rúðuvökvi Óblandaður



HEITI	VÖRUNÚMER
RÚÐUVÖKVI 1 LTR -50°C	044 760442
RÚÐUVÖKVI 4,5 LTR -50°C	044 760440
RÚÐUVÖKVI 20 LTR -50°C	044 760439
RÚÐUVÖKVI 208 LTR -50°C	044 760436

Frost protection mixture ratios:

- Concentrate 100% -50°C
- Mixture 1:1 -20°C
- Mixture 1:2 -15°C.

ÁFYLLINGAREFNI FYRIR AC KERFI



HEITI	VÖRUNÚMER
AC ÁFYLLING M/MÆLI 510Gr EZ C M/LEKAVÖRN. EZ CHILL	102 MAC134
Synthetic refrigerant R-134a Auto A/C recharge	



Ryðvarnarefni





Svart ryðvarnarefni á undirvagna bíla og tækja, tanka, gaspípur, öryggisvíra, og annars staðar sem þarf sterka og góða ryð- og tæringarvörn.

HEITI	VÖRUNÚMÉR
TECTYL UNDIRVAGNS SPREY 600ML	044 887095
TECTYL UNDIRVAGNS 1-LTR DÓS Til að pennsla	044 20035
TECTYL UNDIRVAGNS 1-LTR SVART Fyrir sprautu	044 20050
TECTYL UNDIRVAGNS 5-LTR DÓS	044 20040
TECTYL UNDIRVAGNS 20LTR FATA	044 801431

Ryðvarnarefni svart



Undirvagnsryðvörn



Mjög góð ryðvörn.
Verndar alla málma.
Löng ending.

HEITI	VÖRUNÚMÉR
Fluid film black 333 gr	328 AS11B

Fyrir heimilið, verkstæðið, bóndann, iðnaðinn og fyrir sjávarútveginn.
Ekki eitrað, ekki hættulegt.

Ryðvarnarefni





Ljóst holrúmsspray til ryðvarnar inn í hurðum, fólsum, samskeytum og á öðrum stöðum þar sem erfitt er að komast að.

HEITI	VÖRUNÚMÉR
TECTYL ML HOLRÚMS 1-LTR Fyrir sprautu	044 20080
TECTYL ML HOLRÚMS 5-LTR DÓS	044 20070
RYÐVARNARTAPPAR 100 STK Í POKA	044 3039

Ryðvarnarefni



Fljótpornandi holrúmvas. Besti vinnuhiti 10-25°C

HEITI	VÖRUNÚMÉR
TECTYL HOLRÚMSVAX 500 ML Slanga fylgir með	044 887096

Ryðvarnarefni



Vax sem hægt er að húða með hluti.

HEITI	VÖRUNÚMÉR
TECTYL MULTIPURPOSE TRANSPAREN Vax sem hægt er að húða með hluti og verja.	044 887099

Fyrir bílinn, bátinn, heimilið og iðnaðinn.



Ryðvarnarefni



HEITI

VÖRUNÚMER

Ryðvörn Undercoat gúmmíhúð svört
550gr

200-5700012



Ryðvarnarefni



HEITI

VÖRUNÚMER

Ryðvörn K2 holrúmsvax sprej 500ml
500ml

L330

Ryðvörn K2 holrúmsvax 1 ltr
1 ltr Fyrir loftbyssu

L335

Ryðvörn K2 Durabit spray undirvangs
500ml

L320

Ryðvörn K2 Durabit undirvangs
1 ltr Fyrir loftbyssu

L325

Ryðvörn K2 Durabit undirvangs
1 ltr Dós

L326

Ryðvarnarbyssa með úðabarka K2

L6520



HEITI

VÖRUNÚMER

Tectyl byssa Deluxe

066 SG16

Tectyl byssa með lausum lokum

066 SG14D

Tectyl úðabyssa

066 SG14

Tectyl byssusetur fyrir vax

066 SG18

Grjótvarnar og tectyl byssa 4CR

040 59210001



LUCAS Transmission Fix



HEITI

VÖRUNÚMER

Sjálfskiptinga viðgerðarefni

102 10009

Efnið getur stoppað snuð í sjálfskiptingum, hreinsar ventla og húðar fleti með Polymeric filmu.

Efnið skilar engum árangri ef hlutir í skiptingunni eru brotnir eða reimin eða kúplingspakkningarnar eru útbrunnar. Efnið frískar upp á notaðan gírvökva. Þegar efnið er blandað við sjálfskiptivökvann skal hann vera heitur og bíllinn í lausagangi. Ein flaska dugar á minni skiptingar en tvær á stærri. Efnið er gott til að þétta leka í beinskíptum eða sjálfskiptum kössum.



Hreinsir fyrir sjálfskiptingar



HEITI

VÖRUNÚMER

HREINSIEFNI F/ SJÁLFSKIPTINGAR
500 ml brúsi.

044 887452

Lesið vel leiðbeiningar á umbúðum.
Hreinsar sjálfskiptingar kerfið.
150ml af efnið í 3-6 ltr af olíu.



HEITI

VÖRUNÚMER

VATNSKASSAÞÉTTIR 300ML.
COOLING SYSTEM STOP LEAK 300ml

044 890603

Stoppar leka á áhrifaríkan hátt
Alveg samhæft við allar gerðir af kælivökva



HEITI

VÖRUNÚMER

VATNSKASSAHREINSIR 300ML.
COOLING SYSTEM CLEANER

044 882659

Cooling system Cleaner 300ml

044 882660



HEITI

VÖRUNÚMER

ENGINE OIL STOP LEAK

044 882656

Suitable for all petrol and diesel engines
with all commonly used motor oils.



HEITI

VÖRUNÚMER

ENGINE OIL SYSTEM CLEANER

044 890608

Hentar fyrir bensín- og díselvélar og allar algengar
mótorolíur



HEITI

VÖRUNÚMER

PETROL SYSTEM CLEANER 300ML
Innsþýtingahreinsir bensín 300ml

044 890610



HEITI

VÖRUNÚMER

PETROL SYSTEM PROTECTOR 300ml
Bætiefni og vörn í bensín (E10)
Hreinsar eldsneytiskerfið úr tankinum í brennsluhólfið
Lægri eldsneytiseyðsla

044 890611



HEITI

VÖRUNÚMER

DIESEL SYSTEM CLEANER 300ml

044 890604

Hreinsar fullkomlega díselkerfið
Bætir bruna og dregur úr reykt.



HEITI

VÖRUNÚMER

DIESEL SYSTEM PROTECTOR 300ml
Bætiefni og vörn í dísel.
Hannað til að hjálpa smurningu á dísel innsþýtingarkerfum

044 890605



HEITI

VÖRUNÚMER

DPF CLEANER & REGENERATOR
Hvarfakútshreinsir. **Hreinsar sótkornasíur.**
Fyrir dísel vélar. 1 brúsi 300ml í 40-80 ltr tank.
Lágmark 10ltr af dísel.
Ekki fyrir bifreiðar sem nota AdBlue.

044 890606



HEITI

VÖRUNÚMER

DÍSEL HD HREINSIR FYRIR KERFI
VPS HD DIESEL SYSTEM COMPLETE
500ml **Hreinsar sveppi úr dísel kerfum.**
Fyrir vörubíla og vinnuvélar.
Eykur afl og hreinsar olíuverkið.
Léttir kaldræsingu.

044 55340



HEITI

VÖRUNÚMER

Vatnskassahreinsir 350ml
VSP Radiator Flush

044 VE55187



Efnavara fyrir verkstæðið



HEITI

VÖRUNÚMER

Rakavörn sprej fyrir rafhluti
300ml Electro Protect

044 887044

Startsprej - Motor start
300ml

044 887056

Pakkingaleysir - Gasket Remover
300ml

044 887063

Snertuhreinsir - Contact Cleaner
300ml

044 887066

Hreinsispray All Purpose Cleaner
300ml

044 887069

Hreinsiefni fyrir DPF (sótsíu hreinsir)
300ml

044 887070

Hreinsiefni fyrir EGR skynjara
300ml

044 887071



Lyktareyðir í miðstöðvar.



HEITI

VÖRUNÚMER

Lyktareyðir í miðstöðvar
150ml Airco Refresher

044 892334



BÆTI OG HREINSIEFNI FYRIR BENSÍN OG DÍSELVÉLAR

HEITI

VÖRUNÚMER



SEA FOAM SPÍSSAHR BENSÍN/DIESEL
Spíssahreinsir fyrir bensín og dísel vélar.
Hreinsar innspítungarspíssa og ventla.
Minnkar rakamyndun í bensíntanki.
Bætt úti, mótrolíu, losar um og hreinsar.
Notast með öllum olíum, einnig syntetískum.
Hefur ekki áhrif á súrefnisskynjara.

102 SF16

Sjá nánar á "youtube sea foam sf16 "



SEA FOAM SPÍSSAHR. SPRAY 12oz
340gr

102 SS14

Notið Sea foam-spray til hreinsunar á spíssum eða blöndungi.
Virkar vel sem meðgjöf á innsogskerfi í minni skömmtum (sjá youtube sea foam ss14).
VARÚÐ notið ekki á innsogs kerfi dísel véla.
Sea Foam-spray hreinsar, smyr og ver vélahluti, eykur snerpu, hefur ekki áhrif á súrefnisskynjara.



SEA FOAM

Notist í bensín bíla, og ethanol-blönduðum bílum.
Notist í dísel bíla og bíódísel bíla.
Notist með vélarolíu. Notist með spíssahreinsitækjum
Notist fyrir tví-og fjórgengis vélar.
Notist fyrir fólksbíla, jeppa, vöru-og flutningabíla, báta, vinnuvélar.
Sea foam-spray hreinsar og smyr innsogs kerfi véla.
Losar um og hreinsar vélasót og fitumyndun í brunahólfi..
Notist út í olíu sem hreinsir, þarf ekki að hafa olíuskipti strax á eftir.
Má einning nota með syntetískum olíum.



HEITI

VÖRUNÚMER



Sea foam Marine Pro fyrir báta
591ml Fyrir 2 og 4gensis mótora
Fyrir allar gerðir af bensín og ethanol eldsneyti.
Hreinsar og smyr mikilvægt efra svæði vélar.
Hjálpar til við að draga úr langtíma sliti á vél.
Kemur í veg fyrir tæringu af völdum etanóls og vatns.

102 MP20



Sea foam Deep Creep oil & lubricant
340gr Premium penetrating oil.
Smursprey Penetrating.

102 DC14



Sea foam Bugs B Gone
473ml Skordýrahreinsir mjög öflugur
Hentar vel á bíla, atvinnutæki, húsbíla, hjólhýsi, ferðavagna, báta og margt fleira. Leysir vel upp prótein fitu sem límur skordýrin föst og auðvelda því þrífir til muna.

102 BBG1



Reimasprey 500ml

048 090102

V-Belt spray : Efnið hindrar óæskilegar færslur á beltinu og minnkar ískur. Efnið er ekki ætlað á flatar eða tenntar reimar.

Kapalvörn 500ml sprej

048 090103

Cable Protect: Efnið fælir frá mýs og önnur nagdýr sem hugsanlega hefði áhuga á að naga í sundur rafleiðslunar.

Rakavörn 500ml sprej

048 090104

Impregnation spray : Frábært efni til að rakaverja textíl efni - skó - tjöld og hvaða tauefni sem er. Vatnsfælan góða.

Sílikonsprey 500ml

048 090107

Silicon spray : Efnið er notað til þess að smyrja og vernda plast og gúmmí. Efnið er vatnsfráhrindandi og þolir frá -50°C til + 200°C

Rafeinangrun 500ml sprej

048 090108

Electro protect : Efnið er notað til að þurrka raflagnir og vernda. Smýgur vel inn í alla staði.

Smurefni PTFE 500ml sprej

048 090201

PTFE dry : Efnið er öflugt " Þurrt" smurefni til þess að viðhalda smurningu á efnum úr málm og plasti.

Feiti PTFE sprej 500ml

048 090203

PTFE spray : Alhliða smurefni til að smyrja og vernda vélarlhuti úr málm og plasti. Efnið hefur hitaþol frá -50°C til 250°C.

Feiti hvít sprej 500ml

048 090204

WHITE grease : Feitin er með einstaka viðloðun. Notuð til að smyrja og vernda vélahluti úr málm eða plasti.

Keðjufeiti sprej 500ml

048 090205

Industrial chain grease : Gæða keðjuólía sem smýgur mjög vel á þrönga staði og þykkar þegar hú sest.

Multi sprej 500ml

048 090206

Multi spray : Efnið er alhliða smurfeiti til að vernda og þrifa hluti úr málm og plasti. Efnið er rakapolið og ryð fyrirbyggjandi.

Smursprey Black oil 500ml

048 090300

Black oil : Efnið kemur í veg fyrir slit í festingu í snittuðum tengingum sem verða fyrir miklu vinnuálagi. Efnið er vatnsfráhrindandi, kemur í veg fyrir tæringu og ónæmt fyrir veðri, veikum sýrum og basum.



Koparfeiti sprej 500ml

048 090301

Copper spray : Hágæða koparfeiti sem er sérstaklega ætluð á þá staði sem mikill hiti myndast. Mikið koparinnihald í efningu gerir það að verkum að það þolir meiri hita en áður hefur sést í úðabrusaformi.

Vaselinefeiti sprej 500ml

048 090302

Vaseline spray : Ver stál fyrir vatni þannig að það ryðgar seint. Efnið þolir hitasveiflur frá -30°C til + 160°C

Ryðolía Penetrating sprej 500ml

048 090303

Penetrating oil : Ryðleysir sem smýgur vel í gengjur og losar erfiða bolta og festingar. Efnið hrindir frá sér vökva.

Límsprej 500ml

048 090304

Glue : Lím fyrir varanlega límingu sem og skammtíma límingu. Hentar fyrir pappa, tré, tau og ýmiss plastefni

Kælisprej freezer 500ml

048 090306

Freezer : Efnið er til að snöggekla hluti sem erfitt er að ná í sundur. Efnið kælir niður í -50°C .

Keramik Smurfeiti 500ml

048 090307

Ceramic grease: EP2 smurfeiti/smursprej sem inniheldur keramik, feitin inniheldur enga málma eða a málmagnir. Hentar mjög vel til samsetningar á ólíkum málum og þolir mjög vel hita sem og mikið álag.

Gasket Remover sprej 500ml

048 090403

Gasket Remover : Efnið hefur góða eiginleika til að leysa upp pakkníngarlím sem hefur þornað á vélahlutum.

Suðusprej 500ml

048 090404

Anti Welding : Efnið kemur í veg fyrir að suðuslettur festist við suðusvæðið. Úðinn frá efninu er ekki eldfimur.

Startsprej 500ml

048 090405

Quick Start : Efninu er sprautað inn í lofthreinsarann í nokkrar sekúndur og bíllinn svo ræstur.

Snittolía sprej 500ml

048 090407

Cut & Drill Lubricant : Hágæða bor og snittolía sem dugur vel þar sem mikill hiti myndast og lengir líftíma verkfæranna.

Rykhreinsir sprej 500ml

048 090408

Dust remover : Öflugur brúsi með þrýstingi til að fjarlægja ryk og losa óhreinindi frá stöðum sem erfitt er að ná til.



Lakkleysir 500ml spray

048 090410

Paint remover : Efnið er mjög gott til að fjarlægja gamla málningu af yfirborði hlutar.

Hreinsir fyrir ryðfrítt stál 500ml sprej

048 090503

Stainless steel cleaner: Efnið er gott til að hreinsa ryðfrítt stál og vernda. Einstök formúla efnisins myndar hlífðarfilmur sem ver járnið fyrir óhreinindum.

Glerhreinsir 500ml sprej

048 090504

Glass cleaner : Glerhreinsir 500ml spray
Glerhreinisefnið er fituhreinsandi með gæða eiginleika.

Contact cleaner 500ml sprej

048 090505

Contact cleaner : Efnið er til hreinsunar á rafmagnssnertum og tengjum ýmiskonar. Efnið heldur vel frá raka og drullu.

Vélahreinsir 500ml sprej

048 090506

Engine cleaner : Efnið er notað til að þrifa vélahluti. Efnið hefur mikla uppleysieiginleika og skilur ekkert eftir sig.

Iðnaðarhreinsir 500ml sprej

048 090509

Industrial Cleaner : Alhliða hreinsiefni til að fjarlægja óhreinindi af hlutum úr málm og plasti.

Blöndugahreinsir 500ml sprej

048 090510

Carburettor cleaner : Efnið hreinsar blöndunga bæði innan og utan. Hefur góða hreinsunareiginleika.

Froðuhreinsir 500ml sprej

048 090511

Multi foam cleaner : Efnið er tilvalið í að hreinsa yfirborðs óhreinindi eins og reykjarlykt, blek og fitu.

Alhliðahreinsir 500ml sprej

048 090513

Citrus Cleaner : Efnið er öflugt alhliðahreinsiefni sem hefur góða og hraða virkni. Hreinsar málma og plast.

DPF Hreinsir 500ml sprej

048 090515

DPF Cleaner : Efnið er öflugur hreinsir fyrir sótagnasíur. Hjálpar til við að losa um og fjarlægja sótagnir og önnur efni úr síunni án þess að þurfa að taka hana í sundur.

EGR Hreinsir 500ml sprej

048 090516

EGR Cleaner : Efnið er fljótvirkt hreinsiefni fyrir útblástursloftunarloka, EGR loka. Einnig fyrir loftrásarkerfi og inntaksventla.

Bremsuhreinsir Power 500ml

048 090563

Power Brake Cleaner : Efnið er öflugur bremsuhreinsir og fyrir alla aðra vélahluti.



Ryðólía og fleira frá WD-40

WD-40

HEITI

VÖRUNÚMÉR



WD-40 Multi-Use smursprey 200ml
200ml Multi-Use orginal 47102

WD-40 Multi-Use smursprey 400ml
400ml Multi-Use orginal 47104

WD-40 Multi-Use smursprey með röri
250ml Multi-Use orginal 47784

WD-40 Multi-Use smursprey með röri
450ml Multi-Use orginal 46237

WD-40 Multi-Use smursprey flex rör
400ml Multi-Use orginal, stillanlegt rör 47692

WD-40 Multi-Use smurefni 5 ltr brúsi
5 ltr Multi-Use orginal 46505

WD-40 Ryðólía með röri 400ml
400ml Specialist Penetrant Spray 47383

WD-40 Smurfeiti sprej með röri
400ml Specialist Spray Grease 47385

WD-40 Skerólía með röri 400ml
400ml Specialist Cutting oil 47381

WD-40 White Lithium Grease með röri
400ml Specialist White Lithium Grease 47111

WD-40 PTFE smursprey (þurrsmurn.)
400ml Specialist PTFE spray 47097

WD-40 Sílikon sprej með röri 400ml
400ml Specialist Silicone 47384

WD-40 Snertuhreinsir 400ml
400ml Specialist Contact Cleaner 47380

WD-40 Fituhreinsir 500ml
500ml Specialist Degreaser 47380



Hjóla smurvörur frá WD-40

WD-40

HEITI

VÖRUNÚMÉR



WD-40 Keðjuolía Wet Lube 45777
100ml Specialist Bike wet lube fyrir reiðhjól

WD-40 Keðjuolía Dry lube 45789
100ml Specialist Bike Dry Lube fyrir reiðhjól

WD-40 Fituhreinsir fyrir reiðhjól 45804
500ml Specialist Bike Degreaser

WD-40 Hreinsiefni fyrir reiðhjól 47228
500ml Specialist Bike Clenaer



Koppafeiti



Koppafeiti TRIBOL GR 400-2 PD

HEITI

VÖRUNÚMER

Alhliðasmurfeiti fyrir legur, fóðringar og aðra smurfleti. Inniheldur engin steinefni og hentar því vel í smurkerfi sem gerð eru fyrir NLGI 2 feiti. Vinnuhitastig -30°C til + 140°C. Hrindir vel frá sér vatni og hefur góða viðloðun. Mikil tæringavörn og inniheldur microflux trans.

Typical Characteristics

Name	Method	Units	GR 400-2 PD	GR 400-3 PD
Colour	Visual	-	Brown	
Base Oil	-	-	Lithium Soap / Mineral Oil	
Worked Penetration (60 strokes @ 25 °C/77 °F)	ISO 2137/ASTM D217	0.1 mm	285 - 295	220 - 250
Worked Penetration (100,000 strokes @ 25 °C/77 °F)	ISO 2137/ASTM D217	0.1 mm	35	30
Dropping Point	ISO 2176/ASTM D566	°C/°F	>180/>356	>185/>365
Water Resistance	DIN 51807-1	Rating	1 - 90	1 - 90
Rust Test - EMCOR (distilled water)	ISO 11007/ASTM D6138	Rating	0	n/a
Copper Corrosion (24 hrs, 100 °C/212 °F)	ASTM D4048	Rating	1	1

Subject to usual manufacturing tolerances.

- Koppafeiti GR400-2 PD 400 GR (Longtime 2) **315 15B06E**
- KOPPAFEITI GR400-2 PD 18 KG (Longtime 2) **315 15892C**
- KOPPAFEITI GR400-2 PD 50 KG (Longtime 2) **315 15892D**
- KOPPAFEITI GR400-2 PD 180KG (Longtime 2) **315 15893A**

Góð feiti á smurkerfi - Lincoln og fleira.



Koppafeiti PD0, PD00, PD1, PD2



Koppafeiti TRIBOL GR 100-1 PD

HEITI

VÖRUNÚMER

- KOPPAFEITI GR100-1 PD 400G **315 157CFA**
- KOPPAFEITI GR100-1 PD 50 KG (Longtime PD1) **315 157CE6**
- KOPPAFEITI GR100-0 PD 18 KG (Longtime PD1) **315 1581C2**
- KOPPAFEITI GR100-00 PD 18 KG (Longtime PD00) **315 157D1A**
- KOPPAFEITI GR100-00 PD 50KG (Longtime PD00) **315 15C8BA**
- KOPPAFEITI GR100-2 PD 400GR (Longtime PD2) **315 15C852**
- KOPPAFEITI GR100-2 PD 18KG (Longtime PD2) **315 15C854**
- KOPPAFEITI GR100-2 PD 50KG (Longtime PD2) **315 15C857**

Typical Characteristics

Name	Method	Units	100-00 PD	100-0 PD	100-1 PD	100-2 PD
Appearance	Visual	-	Brown			
Thickener type	-	-	Lithium			
Base oil	-	-	Mineral oil			
Consistency	ISO 2137/ASTM D217	NLGI Grade	00	0	1	2
Density @ 20 °C/68 °F	inhouse method	kg/m³	910	890	890	890
Worked Penetration (60 strokes @ 25 °C/77 °F)	ISO 2137/ASTM D217	0.1 mm	400 - 430	355 - 385	310 - 340	265 - 295
Worked Penetration (100,000 strokes @ 25 °C/77 °F) - change from 60 strokes	ISO 2137/ASTM D217	0.1 mm	-	-	<20	<20
Dropping point	ISO 2176/ASTM D566	°C/°F	-	-	190/374	200/392
Base Oil Viscosity @ 40 °C/104 °F	ISO 3104/ASTM D445	mm²/s	130	130	95	95
Copper Corrosion (24 hrs, 100 °C/212 °F)	ASTM D4048	Rating	1b			
SRV Friction and Wear test (400N/2h/50 °C)	ASTM D5707	coeff. of friction/wear scar diam (mm)	0.08/0.65	0.07/0.65	0.07/0.65	0.07/0.65
Flow pressure @ -35 °C/-31 °F	DIN 51805	hPa	500	1000	1100	1200
Water Resistance	DIN 51807-1	Rating	1 - 90			
DIN Classification	DIN 51502	-	KP 00 N-40	KP 0 N-40	KP 1 N-30	KP 2 N-30
ISO Classification	ISO 6743/9	-	L-XDDB-00	LXDDHB-0	LXCDHB-1	LXCDHB-2

Subject to usual manufacturing tolerances.

Sérhönnuð legufeiti fyrir legur sem snúast hratt til dæmis í móturum og prentvélum. Þykkt NLGI 00 fyrir opna gíra og smurkerfi þar sem krafist er hálflijótandi feiti og NLGI 1&2

Vinnuhitastig -35°C til + 140°C



Matvælafeiti

Koppafeiti GR FS 2



HEITI

VÖRUNÚMER

Matvælafeiti Optileb GR FS 2 380gr

315 159BF3

Advantages

- Physiologically safe
- Tasteless and odorless
- Good adhesion
- Resistant to hot and cold water
- Excellent resistance to cleaning agents and disinfectants
- Compatible with sealing materials resistant to mineral oil
- Temperature application range: -30 °C/-22 °F to +140 °C/+284 °F
- Good behavior at low temperatures

Typical Characteristics

Name	Method	Units	Optileb GR FS 2
Colour	Visual	-	amber
Base oil	-	-	PAO
Thickener type	-	-	Al-complex
Worked Penetration (60 strokes @ 25 °C/77 °F)	ASTM D217/ISO 2137	0.1 mm	295 - 335
Density @ 20 °C/68 °F	IP 530	kg/m ³	835
Dropping point	ASTM D566/ISO 2176	°C/°F	>230/>446

Subject to usual manufacturing tolerances



HEITI

VÖRUNÚMER

Koppafeiti GR 1350-2.5 400gr
(Optipit)

315 158A53

Advantages

- Water and dirt repellent – the grease is still effective in adverse environments
- High load bearing capacity - enables the extension of operating periods even under high loads whilst still maintaining optimum wear protection.
- Establishes a protective layer of MFT – this additive system can effectively increase the load bearing area, therefore reducing unit pressures, operating temperatures and wear which can increase service life of both part and lubricant
- Improved bearing surfaces for longer service life result from the 'running in' effect of MFT
- Extremely low coefficients of friction – energy savings and reduced noise levels
- Good adhesion due to high oil viscosity – the film coating stays on the surface
- Reduction of running-in period

Typical Characteristics

Name	Method	Units	Tribol GR 1350-2.5 PD
Appearance	Visual	-	Brown
Thickener type	-	-	Lithium
Base Oil	-	-	Mineral oil
Consistency	ISO 2137/ASTM D217	NLGI grade	2.5
Density @ 20 °C/68 °F	IP 530	kg/m ³	905
Worked Penetration (60 strokes @ 25 °C/77 °F)	ISO 2137/ASTM D217	0.1 mm	245 - 275
Worked Penetration (100,000 strokes @ 25 °C/77 °F) - change from 60 strokes	ISO 2137/ASTM D217	0.1 mm	max. 25
Dropping point	ISO 2176/ASTM D566	°C/°F	max. 250/max. 482
Base Oil Viscosity @ 40 °C/104 °F	ISO 3104/ASTM D445	mm ² /s	1350
Rust Test - EMCOR (distilled water)	ISO 11007/ASTM D6138	Rating	max. 1/1
Copper Corrosion (24 hrs, 100 °C/212 °F)	ASTM D4048	Rating	max. 1b
SRV Friction and Wear test - 5ae	ASTM D5707	coeff. of friction/wear scar diameter (mm)	0.082/0.53
Oil Separation (168 hrs @ 40 °C/104 °F)	IP 121/DIN 51817	%wt	0.3
Flow pressure @ -20 °C/-4 °F	DIN 51805	hPa	950 - 1350
Water Resistance @ 90 °C	DIN 51807-1	Rating	1

Subject to usual manufacturing tolerances.



HEITI

VÖRUNÚMER

Koppafeiti GR XT2 HT 400gr
Háhitafeiti 180°C - Firetemp
Vinnuhiti -25°C til 180°C

315 08700-448

Advantages

- Outstanding oxidation and thermal stability – provides reliable performance and good lubricant life in severe applications
- Resistant to cold and hot water – the grease film remains on the surface, even in the presence of water
- Easily pumpable in central lubrication systems
- Excellent wear protection – leading to longer bearing life, extended lubrication cycles and helping ensure uninterrupted service in your machinery

Typical Characteristics

Name	Test Method	Unit	GR XT 2 HT
Appearance	Visual	-	Red
Thickener type	-	-	Polyurea
Base oil	-	-	PAO
Consistency	ISO 2137/ASTM D217	NLGI Grade	2
Density @ 20 °C/68 °F	IP 530	kg/m ³	900
Worked Penetration (60 strokes @ 25 °C/77 °F)	ISO 2137/ASTM D217	0.1 mm	265 - 295
Dropping point	ISO 2176/ASTM D566	°C/°F	280/536
Base Oil Viscosity @ 40 °C/104 °F	ISO 3104/ASTM D445	mm ² /s	270
Rust test - Emcor - distilled water	ISO 11007/ASTM D6138	Rating	0/0
Copper Corrosion (24 hrs, 100 °C/212 °F)	ASTM D4048	Rating	1b
Water Resistance	DIN 51807-1	Rating	1 - 90
Oil Separation (168 hrs @ 40 °C/104 °F)	IP 121/DIN 51817	%wt	2.5
Flow pressure @ -20 °C/-4 °F	DIN 51805	hPa	400
FE 9@ 180 °C (B/1500/6000-180) F 50	DIN 51821-02	Report	Pass
SRV Friction and Wear test (400N/ 2 hrs/50 °C)	ASTM D5707	coeff. of friction/wear scar diam (mm)	0.1/0.45

Subject to usual manufacturing tolerances.



HEITI

VÖRUNÚMER

Koppafeiti 936 SF Tannhjólafeiti 18kg

315 15A50F

Molub-Alloy

Typical Characteristics

Name	Method	Units	Molub-Alloy 936 SF Heavy
Density @ 20°C / 59°F	in-house methode	kg/m³	950
Consistency	ISO 2137 / ASTM D217	NLGI Grade	0
Worked Penetration (60 strokes @ 25°C / 77°F)	ISO 2137 / ASTM D217	0.1 mm	345-360
Brookfield Viscosity	ISO 9262 / ASTM D2983	cP	144,000
Base Oil Viscosity @ 40°C / 104°F	ISO 3104 / ASTM D445	mm²/s	2030
Base Oil Viscosity @ 100°C / 212°F	ISO 3104 / ASTM D445	mm²/s	57
Four Ball Weld Load test - Load Wear Index (27°C / 1770 rpm)	ISO 11008 / ASTM D2596	-	130
Four Ball Weld Load test - Weld Point	ISO 11008 / ASTM D2596	kgf	800
Four Ball Wear test - Wear Scar Diameter (40 kgf / 75°C / 1200 rpm / 1 hr)	ISO 51350 / ASTM D2266	mm	< 0.75
Rust Test (distilled water)	ASTM D1743	Pass	Pass
Copper Corrosion (24 hrs, 100°C / 212°F)	ASTM D4048	Rating	1b
Grease Pumpability test - Lincoln Ventmeter	in-house method	psi	500
Lubricating solids, particle size	-	microns	nominal 15, maximum 45

Subject to usual manufacturing tolerances.

Advantages

- Formulated to address environmental concerns - it is free of solvents, lead, antimony and barium
- Forms tough durable film with "cushioning" effect, even under extreme pressures and at very slow speeds; film resists erosion from rain or sleet, and resists peeling in dusty environments
- Resists film destruction by contaminating oils and greases migrating from nearby mechanisms



HEITI

VÖRUNÚMER

SAMSETNINGARFEITI WHITE T 100gr

315 15B6AB

SAMSETNINGARFEITI WHITE T 400 Gr

315 15B6AE

Application

- Universal application as assembly paste.
- Prevents fretting corrosion especially when exposed to vibrations Avoids stick-slip.
- For machines subject to frictional vibrations.
- Avoids squeaking noises in hydraulic cylinders and open lubrication points Temperature application range: -30°C/-22°F to +250°C/+482°F



HEITI

VÖRUNÚMER

CASTROL RED RUBBER GREASE 500G

311 REDGRS-12X.5

Fyrir gúmmíhringi og fl.



WATERPUMP GREASE

311 WPG500

Koppafeiti



HEITI

VÖRUNÚMER

KOPPAFEITI EARTH 2 400 GR
LITHIUM 2

044 895417

Earth Lithium 2	
NLGI grade	2
Soap	Lithium
Colour	Blue
Texture	Very adhesive, Tacky
Density @ 20 °C.	0.90
Application temperature °C.	-20 to + 120
Oil Viscosity, mm ² /s @ 40°C, ISO 3104	200
Dropping Point, °C ISO 2176	190
4-Ball Weld Load, N ASTM D 2596	2500
Water wash out @ 1h/79.4°C, ASTM D 1264	5%
Copper corrosion, degree ASTM D 4048	1

Koppafeiti Rauð á litinn



HEITI

VÖRUNÚMER

Koppafeiti MULTI RED 2 400GR

044 895413

Koppafeiti MULTI RED 2 400GR

044 892653

Skrúfaður tappi M33 x 2.5mm

Alhliðasmurfeiti fyrir legur, fódringar og aðra smurfleti.

Multipurpose Complex Red 2	
NLGI grade	2
Soap type	Lithium complex
Colour	Red
Texture	Tacky
Density @ 20°C	0.90
Application temperature °C	-25 to + 140 short-term 220
Dropping Point, °C ASTM D 2265	270
Oil Viscosity, mm ² /s @ 40°C ISO 3104	220
4-Ball Weld Load, kg ASTM D 2596	315
Water wash out @ 1h/79.4°C ASTM D 1264	5%
Copper corrosion, degree ASTM D 4048	1b

Performance levels

DIN 51502:	KP 2N-20
ISO 6743-9:	L-XBDHB 2



HEITI

VÖRUNÚMER

Koparfeiti 400gr

044 901545



Koppafeiti Brún á litinn

HEITI

VÖRUNÚMÉR

Koppafeiti coloris 23 (Bentone)
400ml

160826

Vinnuhiti -15°C til +160°C

SPECIFICATIONS

- ISO 6743-9: L-XAEEA 2/3
- DIN 51502: MF2/3P - 15

TYPICAL CHARACTERISTICS	METHODS	UNITS	CALORIS 23
Soap/thickener		-	Bentone
NLGI grade	ASTM D 217/DIN 51 818	-	2/3
Color	Visual	-	Brown
Appearance	Visual	-	Smooth/ Buttery
Operating temperature range		°C	-15 to 160
Penetration at 25°C	ASTM D 217/DIN51 818	0.1 mm	250-280
Dropping point	IP 396/NFT 60102 C	°C	infusible
Kinematic viscosity of the base oil at 40°C	ASTM D 445/DIN 51 562-1/ISO 3104/IP71	mm ² /s (cSt)	500

Above characteristics are mean values given as an information.



Koppafeiti Ljós brún á litinn

HEITI

VÖRUNÚMÉR

Koppafeiti Ceran XM 460

182240

400ml Vinnuhiti -25°C til 180°C

Koppafeiti Ceran XM 460

182241

50kg Vinnuhiti -25°C til 180°C

SPECIFICATIONS

- ISO 6743-9: L-XBFIB 1/2
- DIN 51 502: KP1/2R -25

TYPICAL CHARACTERISTICS	METHODS	UNITS	CERAN XM 460 (typical values)
Soap/thickener		-	Calcium sulfonate complex
NLGI grade	ASTM D 217/DIN 51 818	-	1-2
Color	Visual	-	Light brown
Appearance	Visual	-	Smooth
Operating temperature range		°C	- 25 to 180
Kinematic viscosity of the base oil at 40°C	ASTM D 445/DIN 51 562-1/ISO 3104/ IP71	mm ² /s (cSt)	460
Mechanical stability			
Penetration at 25°C	ASTM D 217/DIN 51 818	0.1 mm	280-310
Penetration after 100 000 strokes	ISO 2137	0.1 mm	+6
Shell Roller 100 hours at 80°C	ASTM D 1831 mod	0.1 mm	+10
Shell Roller 100 hours at 80°C + 10% water	ASTM D 1831 mod	0.1 mm	-34
Thermal stability			
Dropping point	IP 396	°C	> 300
Oil release 50 hours, 100 °C	ASTM D 6184	%	2.5
Oil release 168 hours, 40°C	NF T 60-191	%	0.3
Oxidation stability at 99°C +/-0.5°C			
Pressure drop after 100 hours	ASTM D 942	Psi	6
Pressure drop after 500 hours		Psi	13
Antirust properties			
EMCOR, distilled water	ISO 11007	Rating	0-0
EMCOR, synthetic sea water	ISO 11007	Rating	0-0
Copper corrosion, 24 hours at 100°C	ASTM D 4048	Rating	1b
Antiwear and EP properties			
Four ball wear (scar diameter)	ASTM D2266	mm	0.56
Four ball weld load	ASTM D2596	kgf	>400
Cold properties			
Penetration at -20°C	ISO 13737	0.1 mm	95
Flow pressure at -20°C	DIN 51 805	mbar	1310
Flow pressure at 1400 mbar	DIN 51 805	°C	-25
Torque at -20°C			
Starting torque	ASTM D 1478	g.cm	890
After 1 hour		g.cm	72

Above characteristics are mean values given as an information.



Koppafeiti Grá á litinn

HEITI	VÖRUNÚMER
Koppafeiti Copal OGL 0 50kg Vinnuhiti -20°C til 150°C	156087

SPECIFICATIONS

- ISO 6743-9 : L-XBDHB0/00
- DIN 51502 : OGPF0/00N-20

CHARACTERISTICS	METHODS	UNITS	COPAL OGL 0
Soap/thickener		-	Aluminium complex
NLGI grade	ASTM D 217/DIN 51 818	-	0-00
Color	Visual	-	Anthracite
Appearance	Visual	-	Smooth/Buttery
Operating temperature range		°C	- 20 to 150
4 ball weld load	ASTM D2596	kg	> 800
4 ball Wear, Scar diameter	ASTM D2266	mm	< 0.6
FZG A2.8/50 scuffing load step	DIN 51 354	rating	> 12
Anti-rust performance SKF- EMCOR	DIN 51 802/IP220/NFT 60-135/ISO 11007	rating	0-0
Dropping point	IP 396/NFT 60 102 C	°C	> 190
Kinematic viscosity of the base oil at 40°C	ASTM D 445/DIN 51 562-1/ISO 3104/ IP71	mm ² /s (cSt)	> 1000

Above characteristics are mean values given as an information.



Koppafeiti fyrir Hitachi

HEITI	VÖRUNÚMER
Koppafeiti Hitachi EP2 400gr	202687
Koppafeiti Hitachi EP2 15kg	202685
Koppafeiti Hitachi EP2 50kg	202686



Koppafeiti Rauð á litinn

HEITI	VÖRUNÚMER
Koppafeiti Multis Complex EP2 400ml Vinnuhiti -20°C til 160°C	160816
Koppafeiti Multis Complex EP2 18kg Vinnuhiti -20°C til 160°C	140071
Koppafeiti Multis Complex EP2 50kg Vinnuhiti -20°C til 160°C	110371



TYPICAL CHARACTERISTICS	METHODES	UNITS	MULTIS COMPLEX EP 2
Soap/thickener		-	Lithium complex
NLGI grade	ASTM D 217/DIN 51 818	-	2
Color	Visual	-	Red
Appearance	Visual	-	Smooth
Operating temperature range		°C	-20 to 160
Penetration at 25°C	ASTM D 217/DIN51 818	0.1 mm	265-295
Four ball weld load	DIN 51 350-4	daN	280-300
Anti-rust performance SKF- EMCOR	DIN 51 802/IP220/NFT 60-135/ISO 11007	rating	0-0
Dropping point	IP 396/DIN ISO 2176	°C	>275
Kinematic viscosity of the base oil at 40°C	ASTM D 445/DIN 51 562-1/ISO 3104/IP71	mm ² /s (cSt)	165

Above characteristics are mean values given as an information.



Koppafeiti Gul á litinn

HEITI

VÖRUNÚMER



Koppafeiti Multis Complex SHD 100

172826

400 ml

Vinnuhiti -50°C til 160°C

TYPICAL CHARACTERISTICS	METHODS	UNITS	MULTIS COMPLEX SHD 100
Thickener		-	Complex Lithium
Grade NLGI	ASTM D 217/DIN 51 818	-	2
Colour	Visual	-	Yellow
Appearance	Visual	-	Smooth
Temperature range		°C	- 50 to +160
Penetration at 25 °C	ASTM D 217/DIN51 818	0.1 mm	265-295
Penetration at -40°C	NF T 60 171 mod.	0.1 mm	> 160
Low temperature Torque at -40°C	ASTM D 1478	mNm	383
Starting torque			51
Running torque			23
Mechanical stability P100,000 – P60	ASTM D 217/DIN51 818	0.1 mm	pass
Antirust performance	ASTM D 1473	Rating	> 315
4-ball weld load	ASTM D 2596	kgf	0.5
4-ball wear	ASTM D 2266	mm	> 280
Dropping point	IP 396/NFT 60 102 C	°C	100
Base oil viscosity at 40 °C	ASTM D 445/DIN 51 562-1/ISO 3104/ IP71	mm ² /s (cSt)	

Above characteristics are mean values given as an information



Koppafeiti Brún á litinn

HEITI

VÖRUNÚMER



Koppafeiti Multis EP 0 álagspolin

140073

18kg

Vinnuhiti -25°C til 120°C

Koppafeiti Multis EP 0 álagspolin

112261

50kg

Vinnuhiti -25°C til 120°C

TYPICAL CHARACTERISTICS	METHODS	UNITS	MULTIS EP 0
Soap/thickener		-	Lithium/ Calcium
NLGI grade	ASTM D 217/DIN 51 818	-	0
Color	Visual	-	Brown
Appearance	Visual	-	Smooth
Operating temperature range		°C	-25 to 120
Penetration at 25°C	ASTM D 217/DIN51 818	0.1 mm	355 - 385
Flow pressure 1400 mbar	DIN 51 805	°C	- 27
Delimon 7mm, -20°C, 1/10/100 g/min	DIN 51 816-T2	bar/m	1.7/6.5/30
Dropping point	IP 396/DIN ISO 2176	°C	> 170
Kinematic viscosity of the base oil at 40°C	ASTM D 445/DIN 51 562-1/ISO 3104/IP71	mm ² /s (cSt)	150

Above characteristics are mean values given as an information.



HEITI	Koppafeiti	Ljósbrún á litinn	VÖRUNÚMER
Koppafeiti Multis EP 00 álagsþolin			140072
18kg	Vinnuhiti -30°C til 100°C		
Koppafeiti Multis EP 00 álagsþolin			140061
50kg	Vinnuhiti -30°C til 100°C		

TYPICAL CHARACTERISTICS	METHODS	UNITS	MULTIS EP 00
Soap/thickener		-	Lithium/ Calcium
NLGI grade	ASTM D 217/DIN 51 818	-	00
Color	Visual	-	Pale brown
Appearance	Visual	-	Smooth
Operating temperature range		°C	-30 to 100
Penetration at 25°C	ASTM D 217/DIN51 818	0.1 mm	400 - 430
Flow pressure 1400 mbar	DIN 51 805	°C	- 31
Delimon 7mm, -20°C, 1/10/100 g/min	DIN 51 816-T2	bar/m	1,7/6,5/30
Dropping point	IP 396/DIN ISO 2176	°C	> 160
Kinematic viscosity of the base oil at 40°C	ASTM D 445/DIN 51 562-1/ISO 3104/IP71	mm ² /s (cSt)	150

Above characteristics are mean values given as an information.



HEITI	Koppafeiti	Brún á litinn	VÖRUNÚMER
Koppafeiti Multis EP 1 álagsþolin			160828
400ml	Vinnuhiti -30°C til 120°C		
Koppafeiti Multis EP 1 álagsþolin			140074
18kg	Vinnuhiti -30°C til 120°C		
Koppafeiti Multis EP 1 álagsþolin			140053
50kg	Vinnuhiti -30°C til 120°C		

TYPICAL CHARACTERISTICS	METHODS	UNITS	MULTIS EP 1
Soap/thickener		-	Lithium/ Calcium
NLGI grade	ASTM D 217/DIN 51 818	-	1
Color	Visual	-	Brown
Appearance	Visual	-	Smooth
Operating temperature range		°C	- 30 to 120
Penetration at 25°C	ASTM D 217/DIN51 818	0.1 mm	310 -340
Four ball weld load	DIN 51 350-4	daN	260 - 280
Anti-rust performance SKF- EMCOR	DIN 51 802/IP220/NFT 60-135/ISO 11007	rating	0 - 0
Dropping point	IP 396/NFT 60 102 C	°C	> 190
Kinematic viscosity of the base oil at 40°C	ASTM D 445/DIN 51 562-1/ISO 3104/IP71	mm ² /s (cSt)	150

Above characteristics are mean values given as an information.



HEITI	Koppafeiti	Brún á litinn	VÖRUNÚMER
Koppafeiti Multis EP 2 álagsþolin			160804
400ml	Vinnuhiti -25°C til 120°C		
Koppafeiti Multis EP 2 álagsþolin			110384
5kg	Vinnuhiti -25°C til 120°C		
Koppafeiti Multis EP 2 álagsþolin			140069
18kg	Vinnuhiti -25°C til 120°C		
Koppafeiti Multis EP 2 álagsþolin			110385
50kg	Vinnuhiti -25°C til 120°C		
Koppafeiti Multis EP 2 álagsþolin			110382
180kg	Vinnuhiti -25°C til 120°C		

Góð feiti á Smurkerfi - Lincoln og fl.

TYPICAL CHARACTERISTICS	METHODS	UNITS	MULTIS EP 2
Soap/thickener		-	Lithium/ Calcium
NLGI grade	ASTM D 217/DIN 51 818	-	2
Color	Visual	-	Brown
Appearance	Visual	-	Smooth
Operating temperature range		°C	-25 to 120
Penetration at 25°C	ASTM D 217/DIN51 818	0.1 mm	265-295
Four ball weld load	DIN 51 350-4	daN	260-280
Anti-rust performance SKF- EMCOR	DIN 51 802/IP220/NFT 60-135/ISO 11007	rating	0-0
Dropping point	IP 396/DIN ISO 2176	°C	>185
Kinematic viscosity of the base oil at 40°C	ASTM D 445/DIN 51 562-1/ISO 3104/IP71	mm ² /s (cSt)	150

Above characteristics are mean values given as an information.



Koppafeiti Brún á litinn

HEITI

VÖRUNÚMER



Koppafeiti Multis EP 3 álagspolin
400ml Vinnuhiti -20°C til 120°C

160820

TYPICAL CHARACTERISTICS	METHODS	UNITS	MULTIS EP 3
Soap/thickener		-	Lithium/ Calcium
NLGI grade	ASTM D 217/DIN 51 818	-	3
Color	Visual	-	Brown
Appearance	Visual	-	Smooth
Operating temperature range		°C	-20 to 120
Penetration at 25°C	ASTM D 217/DIN51 818	0.1 mm	220-250
Four ball weld load	DIN 51 350-4	daN	260-280
Anti-rust performance SKF- EMCOR	DIN 51 802/IP220/NFT 60-135/ISO 11007	rating	0-0
Dropping point	IP 396/DIN ISO 2176	°C	>185
Kinematic viscosity of the base oil at 40°C	ASTM D 445/DIN 51 562-1/ISO 3104/IP71	mm ² /s (cSt)	150

Above characteristics are mean values given as an information.



Koppafeiti Grá á litinn

HEITI

VÖRUNÚMER



Koppafeiti Multis MS 2 álagspolin
400ml Vinnuhiti -25°C til 120°C

160803

Koppafeiti Multis MS 2 álagspolin
18kg

140076

TYPICAL CHARACTERISTICS	METHODS	UNITS	MULTIS MS 2
Soap/thickener		-	Lithium/ Calcium
NLGI grade	ASTM D 217/DIN 51 818	-	2
Color	Visual	-	Grey
Appearance	Visual	-	Smooth
Operating temperature range		°C	-25 to 130
Penetration at 25°C	ASTM D 217/DIN51 818	0.1 mm	265 - 295
Four ball weld load	DIN 51 350-4	daN	380 - 400
Anti-rust performance SKF- EMCOR	DIN 51 802/IP220/NFT 60-135/ISO 11007	rating	0 - 0
Dropping point	IP 396/DIN ISO 2176	°C	> 185
Kinematic viscosity of the base oil at 40°C	ASTM D 445/DIN 51 562-1/ISO 3104/IP71	mm ² /s (cSt)	150

Above characteristics are mean values given as an information.



Koppafeiti Ljósbrún á litinn

HEITI

VÖRUNÚMER



Koppafeiti Multis XHV 2 álagspolin
400ml Vinnuhiti -20°C til 130°C

160801

Koppafeiti Multis XHV 2 álagspolin
18kg Vinnuhiti -20°C til 130°C

121049

Góð feiti á Smurkerfi - Lincoln og fl.

TYPICAL CHARACTERISTICS	METHODS	UNITS	MULTIS XHV 2
Soap/thickener		-	Lithium/ Calcium
NLGI grade	ASTM D 217/DIN 51 818	-	2
Color	Visual	-	Pale brown
Appearance	Visual	-	Smooth
Operating temperature range		°C	-20 to 130
Penetration at 25°C	ASTM D 217/DIN51 818	0.1 mm	265 - 295
Four ball weld load	DIN 51 350-4	daN	300 - 320
Anti-rust performance SKF- EMCOR	DIN 51 802/IP220/NFT 60-135/ISO 11007	rating	0-0
Dropping point	IP 396/DIN ISO 2176	°C	> 185
Kinematic viscosity of the base oil at 40°C	ASTM D 445/DIN 51 562-1/ISO 3104/IP71	mm ² /s (cSt)	1300

Above characteristics are mean values given as an information.



Koppafeiti Græn á litinn

HEITI	VÖRUNÚMÉR
Koppafeiti Multis ZS 000 120°C 18kg Vinnuhiti -45°C til 120°C	140070
Koppafeiti Multis ZS 000 120°C 50kg Vinnuhiti -45°C til 120°C	110404

TYPICAL CHARACTERISTICS	METHODS	UNITS	MULTI ZS
Soap/thickener		-	Lithium / Calcium
NLGI grade	ASTM D 217/DIN 51 818	-	00/000
Color	Visual	-	Green
Appearance	Visual	-	Smooth
Operating temperature range		°C	- 45 to 120
Penetration at 25°C	ASTM D 217/DIN51 818	0.1 mm	420 - 460
Flow pressure -35°C	DIN 51 805	mbar	56
Delimon 7mm, -20°C, 1/10/100 g/min	DIN 51 816-T2	bar/m	0,25 / 0,98 / 3,62
Dropping point	IP 396/DIN ISO 2176	°C	> 170
Kinematic viscosity of the base oil at 40°C	ASTM D 445/DIN 51 562-1/ISO 3104/IP71	mm ² /s (cSt)	42

Above characteristics are mean values given as an information.



Matvælafeiti

Ljós Beige á litinn

HEITI	VÖRUNÚMÉR
Koppafeiti Nevastane XMF 2 375°C 400gr Vinnuhiti -20°C til 150°C	188475

CHARACTERISTICS	METHODS	UNITS	NEVASTANE			
			XMF 00	XMF 0	XMF 1	XMF 2
Soap/thickener	-	-	Aluminium Complex			
Color	Visual	-	Light beige		Beige	
Appearance	Visual	-	Smooth, homogeneous and slightly tacky			
NLGI grade	ASTM D 217	grade	00	0	1	2
Operating temperature range		°C	from -20°C to +150°C			
Penetration at 25°C	ASTM D 217	0.1 mm	400 - 430	355 - 385	310 - 340	265 - 295
Dropping point	IP 396 /NF T 60102C	°C	> 180	> 200	> 225	> 245
Four ball - wear test	ASTM D 2596	mm	0.6	0.6	< 0.6	< 0.6
Four ball - weld load	ASTM D 2596	kgf	-	-	315	315
Base oil type	-	-	White mineral oil (with polymers)			
Kinematic viscosity at 40 °C	ISO 3104	mm ² /s	120			

Above characteristics are typical values given as an information.



Matvælafeiti

Ljós brúnt á litinn

HEITI	VÖRUNÚMÉR
Koppafeiti Nevastane XS 80 Shuttle 400ml Vinnuhiti -55°C til 150°C	197030

TYPICAL CHARACTERISTICS	METHODS	UNITS	NEVASTANE XS 80
Soap/thickener		-	Calcium sulfonate
NLGI grade	ASTM D 217/DIN 51 818	-	1 - 2
Color	Visual	-	Light brown
Appearance	Visual	-	Smooth
Operating temperature range		°C	- 55 to 150
Penetration at 25°C	ASTM D 217/DIN51 818	0.1 mm	280 - 310
Four ball weld load	ASTM D 2596	kgf	>400
Anti-rust performance SKF- EMCOR	DIN 51 802/IP220/NFT 60-135/ISO 11007	Rating	0 - 0
Flow pressure 1400 mbar	DIN 51805	°C (mbar)	< -55 (1385)
Dropping point	IP 396/NFT 60 102C	°C	> 300
Kinematic viscosity of the base oil at 40°C	ASTM D 445/DIN 51 562-1/ISO 3104/ IP71	mm ² /s (cSt)	80

Above characteristics are mean values given as an information.

- Recommendations:**
 - Store the product at temperatures between 0 and 35°C.
 - Shelf life: 36 months from date of manufacture (unopened).



Matvælafeiti

Ljós brúnt á litinn

HEITI

VÖRUNÚMER

Koppafeiti Nevastane XS 320 190493
 400ml Vinnuhiti -40°C til 180°C
 Koppafeiti Nevastane XS 320 190492
 16kg Vinnuhiti -40°C til 180°C

TYPICAL CHARACTERISTICS

TYPICAL CHARACTERISTICS	METHODS	UNITS	NEVASTANE XS 320
Soap/thickener	-	-	Calcium Sulfonate Complex
Color	Visual	-	Light brown
Appearance	Visual	-	Smooth
NLGI grade	ASTM D 217	grade	1.5
Operating temperature range	-	°C	from -40 to 180
Penetration at 25 °C	ASTM D 217	0.1 mm	280-310
Four ball weld load	ASTM D 2596	kgf	>400
Anti-rust performance SKF-EMCOR	ISO 11007	rating	0 - 0
Dropping point	ISO 2176	°C	> 300
Base oil type	-	-	White oil / PAO (with polymers)
Kinematic viscosity at 40 °C	ISO 3104	mm ² /s	320

Above characteristics are mean values given as an information.

Recommendations:

- Store the product at temperatures between 0 and 35°C.
- **Shelf life: 36 months** from date of manufacture (unopened).



Matvælafeiti

HEITI

VÖRUNÚMER



Koppafeiti Food Grease 1 - Shuttle 9888
400 ml Skrúfaður tappi.
Vinnuhiti -20°C til 150°C

Koppafeiti Food Grease 2 8032
400 ml
Vinnuhiti -20°C til 150°C

Koppafeiti Food Grease HD2- Shuttle 9814
400 ml Skrúfaður tappi.
Vinnuhiti -30°C til 180°C

Koppafeiti Food Grease LT2 6859
400 ml
Vinnuhiti -45°C til 150°C

Koppafeiti Food Grease LT2 - Shuttle 9093
400 ml Skrúfaður tappi.
Vinnuhiti -45°C til 150°C

Koppafeiti Grease HTG hitaþolin 8163
400 ml Matvælavottuð
Vinnuhiti -20°C til 240°C (í stuttan tíma 270°C)

Koppafeiti Grease HTG hitaþolin- 9099
400 ml Skrúfaður tappi Matvælavottuð
Vinnuhiti -20°C til 240°C (í stuttan tíma 270°C)

Koppafeiti Grease MP 2/3 MicPol 9188
400 ml Matvælavottuð
Vinnuhiti -30°C til 145°C

Koppafeiti Grease MP 2/3 MicPol 9893
400 ml Skrúfaður tappi Matvælavottuð
Vinnuhiti -30°C til 145°C

Koppafeiti Grease MP 2/3 MicPol 8023
1000 ml Matvælavottuð
Vinnuhiti -30°C til 145°C

Koppafeiti Grease MP 2/3 MicPol 8553
13 ltr Matvælavottuð
Vinnuhiti -30°C til 145°C

Tækniþlöð og fleira.

Nánari upplýsingar á heimasíðunni kemi.is



Matvælafeiti

HEITI

VÖRUNÚMER

Koppafeiti Grease MP00 Micpol 1 ltr Matvælavottuð Vinnuhiti -25°C til 145°C	8620
Koppafeiti Grease MP00 Micpol 10 ltr Matvælavottuð Vinnuhiti -25°C til 145°C	8029
Koppafeiti White grease túpa 150 ml Matvælavottuð Vinnuhiti -20°C til 150°C	8982



Koppafeiti

HEITI

VÖRUNÚMER

Koppafeiti Grease HD2 - Shuttle 400 ml Skrúfaður tappi. Vinnuhiti -25°C til 160°C	9894
Koppafeiti Grease LS 1/2 400 ml Vatns og saltvatnspolin, inniheldur teflon Vinnuhiti -20°C til 120°C	9189
Koppafeiti Grease LS 1/2 Shuttle 400 ml Vatns og saltvatnspolin, inniheldur teflon Skrúfaður tappi Vinnuhiti -20°C til 120°C	6703
Koppafeiti Grease LS 1/2 13 ltr Vatns og saltvatnspolin, inniheldur teflon Vinnuhiti -20°C til 120°C	8897
Koppafeiti Grease LS2 micPol 400 ml Vatns og saltvatnspolin, inniheldur teflon Vinnuhiti -10°C til 120°C	8267
Koppafeiti Grease LS2 micPol Shuttle 400 ml Vatns og saltvatnspolin, inniheldur teflon Skrúfaður tappi Vinnuhiti -10°C til 120°C	9895
Koppafeiti Grease LS2 micPol 13 kg Vatns og saltvatnspolin, inniheldur teflon Vinnuhiti -10°C til 120°C	8555
Koppafeiti HD2 smursprey m/ MicPol 500ml Fljótandi koppafeiti Vinnuhiti -25°C til 160°C	9528

Tækniblöð og fleira. Nánari
upplýsingar á heimasíðunni kemi.is



MECHANICAL PROPERTIES

N.L.G.I. Grade.....	1/½
Worked Penetration (ASTM D-217)	290-315
Dropping Point (ASTM D-2265)	None
Oxydation Stability (ASTM D-942)	-2
Water Washout (ASTM D-1264)	1.1
Timken OK Load (ASTM D-2509) (Kg/Lb).....	25+/50
4-Ball Wear Test (ASTM D-2266)	0.8mm
Rust Prevention Rating (ASTM D1743)	1a
Operating Temperature Range	260°C to 538°C (500°F to 1000°F)



Háhitakoppafeiti

HEITI

VÖRUNÚMER

Koppafeiti M-Lube UHT
 400ml Háhitakoppafeiti
 Vinnuhiti 260°C til 538°C

600-6731010

Fleygafeiti og fl.

	HEITI	VÖRUNÚMER
	FLEYGAFEITI "HTL" TÚBA 380ml Grófar gengjur	317 542-34047-1
LN400	Fyrir Furukawa	
	FLEYGAFEITI LORAX HTL101 Grófar gengjur 400gr	326 LN400 20X400
	FLEYGAFEITI 500ml F/ FURUKAWA	317 542-34047-2
LK500	FLEYGAFEITI LORAX LK500 Skrúfaðar fínar gengjur.	326 LK500 20X500
	450cc	
	FLEYGAFEITI LORAX 450CC TÚBA 48stk í kassa	326 LORAX-2 48X450
LI400	FLEYGAFEITI LORAX LI400 Feiti f/Interlube. Made in Korea brands Fínar gengjur.	326 LORAX LI400
	LS400	
	FLEYGAFEITI LORAS LS 400G Fínar gengjur. Sverari stútur.	326 LORAX LS400
	FLEYGAFEITI LORAX 600CC 6 stk í búnti og 36stk í kassa	326 2GBHA2900
	FLEYGAFEITI LORAX 25KG	326 2GBHA2-125
	Smursprauta fyrir HTL túpur	066 AK4403
		

Millistikki fyrir fleygafeiti.

HEITI

VÖRUNÚMER



Millistikki á Rammer fleygafeiti.
Blár, túpa fylgir ekki.

326 Rammer



Millistykki á Furukawa og fl (Beka)
Svart, túpa og stöð fylgja ekki.

326 Furukawa (Beka)



Gírolía Aerogear 823 Fyrir þyrlur.

HEITI

VÖRUNÚMER



Gírolía Aerogear 823 fyrir þyrlur
5 ltr

214262

Extreme pressure mineral oil for helicopter gears.

SPECIFICATIONS

● Lubrication of highly stressed helicopter gears.

- **AEROGEAR 823** is certified by DCSEA 255/A and EUROCOPTER
- US: is certified MIL-PRF-6086F (Medium grade)
- UK: DEF-STAN 91-112/1
- Joint Service Designation: OEP-70
- NATO code: **O-155**

TYPICAL CHARACTERISTICS	METHODS	UNITS	AEROGEAR 823
Density at 15 °C	ISO 3675	kg/m ³	867
Kinematic viscosity at 40 °C	ISO 3104	mm ² /s	63.3
Kinematic viscosity at 100 °C	ISO 3104	mm ² /s	8.36
Viscosity index	ISO 2909	-	101
Flash point Open Cup	ISO 2592	°C	240
Pour point	ISO 3016	°C	- 33

Above characteristics are mean values given as an information.



Gírolía Matvælavottuð.



HEITI	VÖRUNÚMER
Gírolía 150 Nevastane EP Matvæla 20 Ltr	190574
Gírolía 150 Nevastane EP Matvæla 208 Ltr	190575
Gírolía 220 Nevastane EP Matvæla 20 Ltr	190578
Gírolía 220 Nevastane XSH Matvæla 20 Ltr	190594
Gírolía 320 Nevastane EP Matvæla 20 Ltr	190581
Gírolía 460 Nevastane EP Matvæla 20 Ltr	190583
Gírolía 680 Nevastane EP Matvæla 20 Ltr	190587

TYPICAL CHARACTERISTICS	METHODS	UNITS	NEVASTANE EP						
			100	150	220	320	460	680	1000
Appearance	Visual	-	clear and bright liquid						
Density @ 15°C	ISO 12185	-	850	875	878	878	877	884	880
Kinematic viscosity @ 40 °C	ISO 3104	mm ² /s	100	150	220	320	460	680	1000
Kinematic viscosity @ 100 °C	ISO 3104	mm ² /s	11,3	14,5	19,5	26,3	29,0	51,0	60,0
Viscosity Index (VI)	ISO 3104	-	100	90	100	110	100	125	110
Flash point C.O.C.	ISO 2592	°C	216	216	227	215	218	240	206
Fire point C.O.C	ISO 2592	°C	246	250	254	243	243	263	268
Pour point	ISO 3016	°C	-12	-9	-9	-9	-9	-9	-9

Above characteristics are mean values given as an information.

Sjá öryggisblað og matvælavottun á heimasíðu kemi.is



Gírolía Finavestan Matvælavottuð Gírolía



Medicinal White Oils.



HEITI	VÖRUNÚMER
Gírolía Finavestan A100B 208 ltr	112412
Gírolía Finavestan A360B 20 ltr	174780

FINAVESTAN white oils meet the requirements of the following specifications⁽¹⁾:

- European Pharmacopoeia, most recent edition⁽²⁾
- US Pharmacopoeia, most recent edition
- US FDA, 21 CFR 178.3620 and 178.3570 White Mineral Oil
- European Regulation 2011/10/CE⁽³⁾ relating to plastic materials and articles intended to come into contact with foodstuffs.

- FINAVESTAN white oils are NSF 3H and H1 registered

TYPICAL CHARACTERISTICS	METHODS	UNITS	FINAVESTAN							
			A 50 B	A 80 B	A 100 B	A 180 B	A 210 B	A 300 B	A 360 B	A 520 B
Saybolt Color (Min.)	ASTM D 156	-	+ 30	+ 30	+ 30	+ 30	+ 30	+ 30	+ 30	+ 30
Kinematic viscosity @ 40 °C	ASTM D 445	mm ² /s	8	15	23	30	40	62	68	100
Density @ 20 °C	ASTM D 4052	kg/m ³	830	854	856	858	860	862	864	868
Pour point (Max.)	ASTM D 97	°C	- 6	- 6	- 6	- 6	- 9	- 12	- 12	- 9
Flash point (Min.)	ASTM D 92	°C	150	180	195	200	210	236	240	250



Gírolía Carter EP

HEITI

VÖRUNÚMER

Gírolía Carter EP 68 20 ltr	112508
Gírolía Carter EP 68 208 ltr	110497
Gírolía Carter EP 100 20 ltr	110484
Gírolía Carter EP 150 20 ltr	110487
Gírolía Carter EP 220 20 ltr	110490
Gírolía Carter EP 320 20 ltr	112532
Gírolía Carter EP 460 20 ltr	110495
Gírolía Carter EP 680 20 ltr	112534

SPECIFICATIONS

- DIN 51517 Part 3 - CLP
- ISO 12925-1 category CKD/CKSMP
- AGMA 9005-F16 AS
- SEB 181226
- JIS K 2219:2006 (Class 2)
- Chinese GB 5903 L-CKD
- US STEEL 224

APPROVALS

- FLENDER
- CMD GEARS
- SEW
- ZF
- BONFIGLIOLI
- DB SANTASALO
- NORD GETRIEBE
- ZOLLERN and many others

TYPICAL CHARACTERISTICS

Properties	Units	Standards	Carter EP							
			68	100	150	220	320	460	680	1000
Density at 15 °C	kg/m ³	ISO 3675	875	882	889	895	901	895	894	900
Viscosity at 40°C	mm ² /s	ISO 3104	68	100	150	220	320	460	680	1000
Viscosity at 100°C	mm ² /s	ISO 3104	8.9	11.3	14.7	19	24.3	34.3	45	43.5
Viscosity index	-	ISO 2909	106	98	97	97	97	113	112	80
Open cup Flash Point	°C	ISO 2592	228	222	238	244	248	256	224	244
Pour point	°C	ISO 3016	-33	-27	-24	-18	-12	-12	-12	-9
FZG A/8.3/90	Fail stage	DIN 51354/2	14 pass	14 pass	14 pass	14 pass	14 pass	14 pass	12 pass	12 pass
FZG Micro pitting GFT Class	Fail stage	FVA 54	-	10 high	10 high	10 high	10 high	10 high	10 high	10 high



Gírolía Carter SH

HEITI VÖRUNÚMER

Gírolía Carter SH 150 20 ltr	112537
Gírolía Carter SH 150 208 ltr	112461
Gírolía Carter SH 220 20 ltr	112718
Gírolía Carter SH 220 208 ltr	112462
Gírolía Carter SH 1000 20 ltr	112552

SPECIFICATIONS

International specifications

Manufacturers

- DIN 51517 - 3 CLP
- ISO 12925-1 CKSMP
- AISI 224
- CINCINNATI MILACRON
- DAVID BROWN
- SIEMENS-FLENDER (VG 150 to VG 680)
- USINOR FT 161
- MÜLLER WEINGARTEN
- AGMA 9005 - E02

TYPICAL CHARACTERISTICS	METHODS	UNITS	CARTER SH							
			68	100	150	220	320	460	680	1000
Density at 15 °C	ISO 3675	kg/m ³	850	853	856,5	859,7	861,7	863,3	864,9	869,5
Viscosity at 40 °C	ISO 3104	mm ² /s	68	100	147,9	220,1	313,8	454,7	676,8	997,8
Viscosity at 100 °C	ISO 3104	mm ² /s	11.5	15.3	19,4	26,2	34,6	46,6	64,0	85,6
Viscosity index	ISO 2909	-	154	153	150	152	155	160	165	169
Open cup flash point	ISO 2592	°C	242	255	235	242	242	248	250	229
FZG Micropitting	FVA 54 IIV	-	-	-	-	10 +	10 +	10 +	10 +	10 +
FZG A/8.3/90	DIN 51 354/2	-	>12	>12	> 13	> 13	> 13	> 13	> 13	> 13
Pour point	ISO 3016	°C	-48	-45	-45	-45	-42	-40	-39	-28



Gírolía Carter SY

HEITI VÖRUNÚMER

Gírolía Carter SY 220 20 ltr	110514
---------------------------------	--------

SPECIFICATIONS

International specifications

Manufacturers

- DIN 51517 Part 3 ⇒ group CLP
- NF-ISO 6743-6 category CKS/CKT
- DAVID BROWN, CMD

CARACTERISTIQUES	METHODS	UNITS	CARTER SY				
			150	220	320	460	680
Density at 15°C	ISO 3675	kg/m ³	1004	1004	1003	1003	1002
Viscosity at 40°C	ISO 3104	mm ² /s	150	220	320	460	640
Viscosity at 100°C	ISO 3104	mm ² /s	23	34	50	71	95
Viscosity index	ISO 2909	-	185	202	220	230	240
Flash point (open cup)	ISO 2592	°C	230	230	230	230	230
Pour Point	ISO 3016	°C	-33	-30	-30	-27	-27



Gírolía Carter XEP

HEITI

VÖRUNÚMER

Gírolía Carter XEP 220 20 ltr	158891
Gírolía Carter XEP 220 208 ltr	156912
Gírolía Carter XEP 320 208 ltr	156759
Gírolía Carter XEP 460 208 ltr	156656
Gírolía Carter XEP 680 20 ltr	156659B
Gírolía Carter XEP 680 208 ltr	156659

SPECIFICATIONS

International specifications

- DIN 51517 Part 3 ⇒ CLP group
- ISO 12925 CKD category

OEM's specifications

- AGMA 9005 - D94
- US STEEL 224
- DAVID BROWN

TYPICAL CHARACTERISTICS	METHODS	UNITS	CARTER XEP				
			150	220	320	460	680
Viscosity at 40°C	ISO 3104	mm ² /s	150	220	320	460	680
Viscosity at 100°C	ISO 3104	mm ² /s	14,6	18.8	24	30,4	35,8
Viscosity index	ISO 2909	-	96	95	95	95	85
Density at 15°C	ISO 3675	kg/m ³	889	893	898	904	920
V.O. flash point	ISO 2592	°C	>230	>230	>230	>230	>230
Pour point	ISO 3016	°C	-27	-24	-18	-12	-9
FAG Fe8, wear	DIN 51819-3	mg	< 10	< 10	< 10	< 10	< 10
FZG A/8.3/90	DIN 51 354/2	Stage	>13	> 13	> 13	> 13	> 13
FZG Micropitting	FVA 54	Failure stage		>10	>10	>10	>10
Seq 3 foaming	ISO 6614	/GFT		/High	/High	/High	/High
		ml/ml	0/0	0/0	0/0	0/0	0/0



Gírolía

HEITI

VÖRUNÚMER



Gírolía Optigear BM320 20ltr	315 145B63
------------------------------	------------

Typical Characteristics

Name	Method	Units	68	100	150	220	320	460	680	1000	1500	3000
Colour	visual	-	brown	brown	brown	brown	brown	brown	brown	brown	brown	brown
ISO Viscosity Group	-	-	68	100	150	220	320	460	680	1000	1500	3000
Density @ 15°C / 59°F	ISO 12185 / ASTM D4052	kg/m ³	890	895	900	905	910	910	920	930	930	930
Kinematic Viscosity @ 40°C / 104°F	ISO 3104 / ASTM D445	mm ² /s	68	100	150	220	320	460	680	1000	1500	3000
Kinematic Viscosity @ 100°C / 212°F	ISO 3104 / ASTM D445	mm ² /s	9.1	11.7	15.0	19.4	24.9	31.8	38.3	47.4	64.2	119.8
Viscosity Index	ISO 2909 / ASTM D2270	-	110	105	100	100	100	100	93	90	95	110
Flash Point - open cup method	ISO 2592 / ASTM D92	°C °F	220 428	220 428	225 437	230 446	235 455	240 464	245 473	250 482	235 455	220 428



Keðjufeiti



Keðjuolía

HEITI

VÖRUNÚMER

Sérhönnuð keðjumsurolía sem hefur þá eiginleika að smjúga inn í liði keðjunnar og smyrja þar sem þörfin er mest. Hefur mjög góða viðloðun og hendir frá sér vatni og óhreinindum.

Keðjuspray Viscogen KL23 400ml

315 156A39

Keðjuolía Viscogen KL23 4,5kg

315 07207-042



Ryðverjandi og ryðlosandi olía með einstaklega góða smureiginleika. Smýgur hratt og vel í gegnum raka og ryð og losar um fasta hluti.

PENETRANT WDP 5 LTR

315 09503-041



Keðjuolía



HEITI

VÖRUNÚMER

Keðjuolía 3,78 lítrar

102 75106

Keðjuolía



Keðjuolía



HEITI

VÖRUNÚMER

Keðjuolía Cobra Light
3,78 ltr

FBB0011226

Keðjuolía fyrir lanbúnaðartæki og keðjusagir.



Fluid film vörur



HEITI

VÖRUNÚMER

FLUID FILM SPREY 11.75 oz 333g

328 AS11

FLUID FILM 1 GALLON

328 AS01

FLUID FILM 5 GALLON

328 AS05

FLUID FILM 205 LÍTRAR

328 FLUIDAS

Smurdælar lincoln



Smurdælar lincoln

2 og 4 Lítra hús.

P203

317 644-37424-1	E1	SMURDÆLA 203-2XN-1K6-24-1A1.10-V10	24 Volt
317 644-37426-1	E2	SMURDÆLA P203-E-2XN-600-24-AA00FB00-V10A 2 kg box 2 tengi 24 VOLT	24V
317 644-37425-1	E2	SMURDÆLA 203-2XN-1K6-12-2A1.10-V10	12 Volt
317 644-37480-1	E2	SMURDÆLA P203-4XNBO-1K6-24-2A1.10 4 kg box 2 tengi	24 Volt



1 Lítra hús.

P502

317 658-41219-4	E1	SMURDÆLA P502-1XN-1K6-12-1A1.10-V20	12 Volt
317 658-41219-2	E1	SMURDÆLA P502-1XN-1K6-24-1A1.10-V20	24 Volt



Dæluement fyrir 203 og 215 smurdælar



HEITI	MAGN	VÖRUNÚMER
Dæluement f/203 5mm	2,0cm ³ /min	317 600-26875-2
Dæluement f/203 6mm	2,8cm ³ /min	317 600-26876-2
Dæluement f/203 7mm	4,0cm ³ /min	317 600-26877-2
Dæluement f/215 6mm		317 600-25046-3
Dæluement f/215 6mm		317 600-25047-3

Öryggisventlar fyrir smurdælar



HEITI	VÖRUNÚMER
Öryggisventill SVTE-350 1/4"-D6	317 624-28894-1
Öryggisventill 270 Bar	317 624-28892-1
Öryggisventill 350 Bar með kopp	317 624-28896-1
Öryggisventill 350 Bar QUICK	317 624-28860-1
Nippil ró f/öryggisventil 6L	317 223-13032-2
Krumpuhólkur f/öryggisloka	317 223-12295-3

317 519-34339-4

STIMPILSKYNJARI M/7 METRA KAPLI
FYRIR 230V AC DÆLU



SMUR-DEILIR



GERÐ	FJÖLDI ÚRTAKA	VÖRUNÚMER
SSV 6	6	317 619-26473-1
SSV 8	8	317 619-25730-2
SSV 10	10	317 619-26841-1
SSV 12	12	317 619-25731-2
SSV 14	14	317 619-28862-1
SSV 16	16	317 619-28863-1
SSV 18	18	317 619-28864-1
SSV 20	20	317 619-28865-1
SSV 22	22	317 619-28866-1

SMUR-DEILIR



GERÐ	FJÖLDI ÚRTAKA	VÖRUNÚMER
SSV 6-K	6	317 619-26474-3
SSV 8-K	8	317 619-25754-4
SSV 10-K	10	317 619-26842-2
SSV 12-K	12	317 619-25755-4
SSV 14-K	14	317 619-28871-1

Áfyllistútar fyrir smurkerfi Lincoln



HEITI	STÆRÐ	VÖRUNÚMER
ÁFYLLISTÚTUR FYRIR LINCOLN KERFI	M22	322 100-208
ÁFYLLISTYKKI VINKIL 115 mm M22 FYRIR LINCOLN KERFI		322 5022-103
ÁFYLLISTYKKI VINKIL 80 mm M22 FYRIR LINCOLN KERFI		322 5022-104

Áfyllistútar fyrir smurkerfi BEKA-VOGEL



HEITI	STÆRÐ	VÖRUNÚMER
ÁFYLLISTÚTUR FYRIR BEKA- VOGEL KERFI	M20	322 100-200
ÁFYLLISTYKKI VINKIL 115 mm M20		322 5022-101



HEITI	STÆRÐ	VÖRUNÚMER
ÁFYLLISSPRAUTA FYRIR SMURKERFI		322 100-201

Áfyllistútar fyrir smurkerfi Quick hún



HEITI	STÆRÐ	VÖRUNÚMER
ÁFYLLISTÚTUR QUICK HÚN	1/4"	322 100-205-1/4
HLÍÐARHETTA RAUÐ HÚN		322 400-029

Áfyllistútar fyrir smurkerfi Quick hann



HEITI	STÆRÐ	VÖRUNÚMER
ÁFYLLISTÚTUR QUICK HANN	1/4"	322 100-206-1/4
HLÍÐARHETTA RAUÐ HANN		322 400-025

Nipplar fyrir smurkerfi í lincoln dælur og fleira



HEITI	STÆRÐ	VÖRUNÚMER
NIPPILL	M22 X 1/4"	322 100-209-22X1,5
NIPPILL	M20 X 1/4"	322 100-209-20X1,5

Nippill fyrir CAT



HEITI	STÆRÐ	VÖRUNÚMER
NIPPILL STÓR F/ CAT		322 1021-102

QUICK kúplingstengi



HEITI	VÖRUNÚMER
QUICK TENGI M/ BAKFLÆÐI Fyrir rótortilt	317 4-2340

FESTISTYKKI f/ 100-225	322 100-227
------------------------	-------------



QUIK-TENGI F/ RÓTORTILT	314 60450
-------------------------	-----------

Té nipplar og smurkoppar



HEITI	VÖRUNÚMER
TÉ-NIPPILL 1/8" BANJO 1/8" GENGJUR 2 INN - 1 ÚT	322 100-324
SMURKOPPUR HÁÞRÝSTUR R1/8"	322 250-003-RV

Úttaksventill 6mm



HEITI	FYRIR 6MM	VÖRUNÚMER
Úttaksventill komplett 6mm m/R		317 504-30344-4
1. Nippilró LL F/6mm Rör		317 223-12374-9
2. Krumpuhólkur F/6mm Rör		317 223-12295-2

Tappi fyrir smurdeila



HEITI	VÖRUNÚMER
Tappi fyrir smurdeila	317 303-17499-3

Slönguhólks ró fyrir þrýstislanga 8,4 X 2,1 FF



HEITI	VÖRUNÚMER
Slönguhólks ró	317 432-23031-1

Slönguhólkur beinn fyrir 6mm rör

6mm



HEITI	VÖRUNÚMER
Slönguhólkur beinn standard	317 432-24162-1
Slönguhólkur beinn langur	317 432-23067-1
Slönguhólkur tvítengdur	322 100-061
Slönguhólkur f/6LL Ró	322 3510-101

Slönguhólkur boginn 90° fyrir 6mm rör

6mm



HEITI	VÖRUNÚMER
Slönguhólkur 90° stuttur	317 532-30739-1
Slönguhólkur 90° langur	317 532-30738-1
Slönguhólkur 90° langur með gróp	322 100-056-NUT

Slönguhólkur boginn 45° fyrir 6mm rör

6mm



HEITI	VÖRUNÚMER
Slönguhólkur 45° stuttur	317 532-32183-1
Slönguhólkur 45° Langur með gróp	322 100-058-NUT

Nippill beinn fyrir 6mm rör

6mm



HEITI	STÆRÐ	VÖRUNÚMER
Nippill f/6mm rör beinn	6x1mm	317 223-12533-9
Nippill f/6mm rör beinn	8x1mm	317 223-13023-1
Nippill f/6mm rör beinn	10x1mm	317 223-12271-7
Nippill f/6mm rör beinn	1/8" R	317 223-12270-7
Nippill f/6mm rör beinn	1/4" R	317 223-12477-8

Nippill vinkil fyrir 6mm rör

6mm



HEITI	STÆRÐ	VÖRUNÚMER
Nippill f/6mm rör vinkill	6x1mm	317 223-13023-2
Nippill f/6mm rör vinkill	8x1mm	317 223-13023-3
Nippill f/6mm rör vinkill	10x1mm	317 223-13021-3
Nippill f/6mm rör vinkill	1/8" R	317 223-12485-9
Nippill f/6mm rör vinkill	1/4" R	317 223-12380-6

Samtengi fyrir 6mm rör

6mm



HEITI	VÖRUNÚMER
Samtengi f/6mm rör	317 223-12482-9
Samtengi f/6mm rör í 4mm nælonrör 4mm í annan endan og 6mm í hinn	322 104-000-6
Samtengi f/6mm rör í 8mm nælonrör 6mm í annan endan og 8mm í hinn	322 106-000-8
Samtengi vinkil fyrir 6mm rör.	322 1015-100

T-stykki fyrir 6mm rör

6mm



HEITI	VÖRUNÚMER
T-Stykki f/6mm rör	317 223-12484-9
Samtengi f/smur-deili Tengja saman úttak 1 og 2	317 519-31826-1

Snúningsnippill beinn



HEITI	STÆRÐ	VÖRUNÚMER
Snúningsnippill beinn	1/8-1/8	317 223-12567-3
Snúningur fyrir smursprautu	1/8-1/8	305 7331921

Snúningsnippill vinkil



HEITI	STÆRÐ	VÖRUNÚMER
Snúningsnippill vinkil	1/8-1/8	317 223-12567-1

Millistykki vinkil 90°



< INN

ÚTTAK

HEITI	STÆRÐ		VÖRUNÚMER
	INN TAK	ÚTTAK	
Millistykki 90° vinkil	8mm	x 6mm	322 100-721
Millistykki 90° vinkil	8mm	x 8mm	322 100-722
Millistykki 90° vinkil	8mm	x 10mm	322 100-723
Millistykki 90° vinkil	8mm	x 1/8"	322 100-724
Millistykki 90° vinkil	10mm	x 6mm	322 5011-105
Millistykki 90° vinkil	10mm	x 8mm	322 100-732
Millistykki 90° vinkil	10mm	x 10mm	322 100-733
Millistykki 90° vinkil	10mm	x 1/8"	322 100210105
Millistykki 90° vinkil	1/8"	x 1/8"	322 100-744

Millistykki vinkil 45°



< INN

ÚTTAK

HEITI	STÆRÐ		VÖRUNÚMER
	INN TAK	ÚTTAK	
Millistykki 45° vinkil	8mm	x 6mm	322 100-821
Millistykki 45° vinkil	8mm	x 8mm	322 100-822
Millistykki 45° vinkil	8mm	x 10mm	322 100-823
Millistykki 45° vinkil	10mm	x 10mm	322 100-833
Millistykki 45° vinkil	1/8"	x 1/8"	322 100-844

Gegnumtak fyrir 6mm



HEITI	STÆRÐ	VÖRUNÚMER
Gegnumtak f/6mm. 6x1 innan gengjur (vantar smurkoppinn sem er 6mmx1)		322 1020-002

Framlengingar og minnkanir

STÆRÐ



HEITI	LENGD	INN TAK	ÚTTAK	VÖRUNÚMÉR
Minnkun	18mm	8mm	x 6mm	322 100-120
Minnkun	15mm	8mm	x 1/4" UNF-28	305 5628129
Framlenging	18mm	8mm	x 8mm	322 100-130
Framlenging	32mm	8mm	x 8mm	322 100-132
Framlenging	62,5mm	8mm	x 8mm	322 100-135
Minnkun	20mm	10mm	x 8mm	322 0411600106
Framlenging	23mm	10mm	x 10mm	322 100-141
Framlenging	35mm	10mm	x 10mm	322 100-145
Framlenging	50mm	10mm	x 10mm	322 100-146



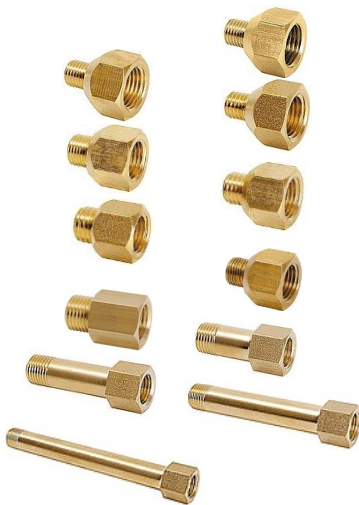











Framlenging	18mm	1/8"	x 1/8"	322 100-152
Framlenging	23mm	1/8"	x 1/8"	322 100-148
Framlenging	35mm	1/8"	x 1/8"	322 100-149
Minnkun	40mm	1/8"	x 8mmx1	317 304-M8x1
Minnkun	40mm	1/8"	x 8mmx1,25	317 304-M8x1,25
Minnkun	40mm	1/8"	x 10mmx1,5	317 304-M10x1,5
Framlenging	50mm	1/8"	x 1/8"	322 100-153



Minnkun	15mm	1/4"	x 6mmx1	310 260011511
Minnkun	15mm	1/4"	x 8mmx1	310 260011514
Minnkun	15mm	1/4"	x 8mmx1,25	310 104839
Minnkun	15mm	1/4"	x 10mmx1	310 260011518
Minnkun	15mm	1/4"	x 10mmx1,5	310 260011520
Minnkun	15mm	1/4"	x 12mmx1,5	310 260011526
Minnkun	15mm	1/4"	x 1/8" kopar	310 260011501
Framlenging	18mm	1/4"	x 1/4" kopar	310 260011151
Framlenging	30mm	1/4"	x 1/4" kopar	310 104854
Framlenging	45mm	1/4"	x 1/4" kopar	310 104855
Framlenging	75mm	1/4"	x 1/4" kopar	310 260011702
Framlenging	115mm	1/4"	x 1/4" kopar	310 260011705



Framlenging	21mm	3/8"	x 1/8" Ryðfr	308 999
-------------	------	------	--------------	---------

<p>6x1mm 317 223-12533-9</p>  <p>4 stk</p>	<p>6x1mm 317 223-13023-2</p>  <p>4 stk</p>	<p>8x1mm 317 223-13023-1</p>  <p>4 stk</p>	<p>8x1mm 317 223-13023-3</p>  <p>4 stk</p>	<p>6mm 317 223-12482-9</p>  <p>4 stk</p>
<p>317 432-23031-1 10 stk</p> 	<p>90° 317 532-30739-1 2 stk 317 532-30738-1 2 stk</p> 	<p>10x1mm 317 223-12271-7</p>  <p>4 stk</p>	<p>10x1mm 317 223-13021-3</p>  <p>4 stk</p>	<p>066 SC128 1 STK</p> 
<p>317 432-24162-1 6 stk</p> 	<p>45° 317 532-32183-1 2 stk</p> 	<p>1/8" R 317 223-12270-7</p>  <p>10 stk</p>	<p>1/8" R 317 223-12485-9</p>  <p>10 stk</p>	
<p>317 504-30344-4 2 STK</p> 	 <p>VARAHLUTABOX</p>		<p>18mm 1/8" x 1/8" 2 stk 322 100-152 23mm 1/8" x 1/8" 2 stk 322 100-148</p> 	

Skeifan 2, 108 Reykjavík, sími 5305900

TILBOÐSVERÐ 24.800- M/VSK

Vörunúmer

317 999999

6mm

Smurslöngur - Nælonslanga 6mm



HEITI	STÆRÐ	VÖRUNÚMER
Nælonrör feitisfyllt 100 metrar á rúllu	6 x 1,5mm	317 504-36041-2
Nælonrör tómt 100 metrar á rúllu	6 x 1,5mm	317 504-36042-2

Smurslöngur - Gúmmí þrýstislanga



HEITI	STÆRÐ	VÖRUNÚMER
Smurkerfisslanga 50 metrar á rúllu Gúmmíslanga	8,4 x 2,1mm Feitísfyllt.	317 504-36033-3
Smurkerfisslanga 50 metrar á rúllu Gúmmíslanga	8,4 x 2,1mm án feiti.	317 111-35114-1

Hlífðarslöngur fyrir smurkapla



HEITI	STÆRÐ	VÖRUNÚMER
Hlífðarslöngu spirall 25metrar á rúllu	10mm	317 113-35075-3
Hlífðarslöngu spirall 25metrar á rúllu	6mm	322 100-040



HEITI	VÖRUNÚMER
SLÖNGUKLIPPUR 6-25MM BLAÐ Í SLÖNGUKLIPPUR	066 HCA25 066 HCA25/B
SLÖNGUKLIPPUR 3-10MM	066 SC128

Nippilblokkir 10x1 mm

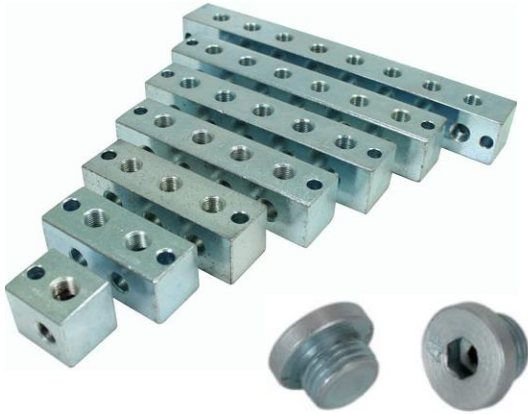

HEITI	STÆRÐ	VÖRUNÚMÉR
Nippilblokk 1 úttak	10x1mm	322 100-211
Nippilblokk 2 úttök	10x1mm	322 100-212
Nippilblokk 3 úttök	10x1mm	322 100-213
Nippilblokk 4 úttök	10x1mm	322 100-214
Nippilblokk 5 úttök	10x1mm	322 100-215
Nippilblokk 6 úttök	10x1mm	322 100-216
Nippilblokk 8 úttök	10x1mm	322 100-218
TAPPI Í NIPPILBLOKK	10X1mm	322 100-243

Nippilblokkir **Ryðfríar**. 10X1 mm



HEITI	STÆRÐ	VÖRUNÚMÉR
NIPPILBLOKK 1-ÚTTÖK RYÐFRÍTT		322 5029-201
NIPPILBLOKK 2-ÚTTÖK RYÐFRÍTT		322 5029-212
NIPPILBLOKK 4-ÚTTÖK RYÐFRÍTT		322 5029-214
NIPPILBLOKK 6-ÚTTÖK RYÐFRÍTT		322 5029-216
NIPPILBLOKK 8-ÚTTÖK RYÐFRÍTT		322 5029-218

Slönguklemmur fyri bolta



HEITI	BOLTA STÆRÐ	VÖRUNÚMÉR
Slönguklemma 8mm	6mm	322 100-608
Slönguklemma 12mm	5mm	322 100-512
Slönguklemma 12mm	6mm	322 100-612
Slönguklemma 14-15mm	6mm	322 100-615
Slönguklemma 16mm	6mm	322 100-616
Slönguklemma 18mm	6mm	322 100-618
Slönguklemma 20mm	6mm	322 100-620
Slönguklemma 25mm	6mm	322 100-625

Þrýstimælir og festing.



HEITI	VÖRUNÚMÉR
VÖKVAF.ÞRÝSTIMÆLIR 63MM 400 BA	245 2263-0-4000
MÆLATENGI 1/4" Í 6MM L	322 106-245-L

QUICK Fyrir slöngu 8,6 x 1,5 QUICK Fyrir slöngu 8,6 x 1,5 QUICK

Úttaksventill QUICK fyrir 6mm

6mm

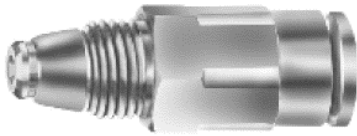

HEITI	VÖRUNÚMER
Úttaksventill QUICK Háþrýstur	317 226-14091-4

QUICK Nippilar beinir fyrir 6mm Háþrýstir

6mm



HEITI	STÆRÐ	VÖRUNÚMER
QUICK Nippill háþrýstur	6x1mm	317 226-14111-4
QUICK Nippill háþrýstur	8x1mm	317 226-14111-2
QUICK Nippill háþrýstur	10x1mm	317 226-14111-3
QUICK Nippill háþrýstur	1/8"	317 226-14111-1

QUICK Nipplar vinkil fyrir 6mm Háþrýstir

6mm



HEITI	STÆRÐ	VÖRUNÚMER
QUICK Nippill háþrýstur	6x1mm	317 226-14123-4
QUICK Nippill háþrýstur	8X1mm	317 226-14123-2
QUICK Nippill háþrýstur	10x1mm	317 226-14123-3
QUICK Nippill háþrýstur	1/8"	317 226-13753-9

QUICK Snúningsnippill vinkil fyrir 6mm Háþrýstir

6mm



HEITI	STÆRÐ	VÖRUNÚMER
QUICK Snúningsnippill	6x1mm	317 226-14157-3
QUICK Snúningsnippill	8x1mm	317 226-14157-1
QUICK Snúningsnippill	10x1mm	317 226-14157-2
QUICK Snúningsnippill	1/8"	317 226-13756-9

QUICK Té fyrir 6mm Háþrýst

6mm



HEITI	STÆRÐ	VÖRUNÚMER
QUICK Té Háþrýst		317 226-14097-4

QUICK Samtengi fyrir 6mm Háþrýst

6mm



HEITI	STÆRÐ	VÖRUNÚMER
QUICK Samtengi háþrýst		317 226-13773-4

QUICK Fyrir nælonrör 6 x 1,5 QUICK Fyrir nælonrör 6 x 1,5 QUICK

Úttaksventill QUICK fyrir nælonrör 6mm

6mm

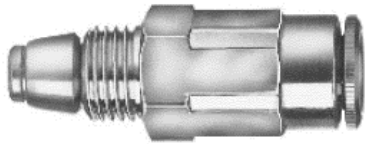

HEITI	STÆRÐ	VÖRUNÚMER
Úttaksventill QUICK f/nælonrör		317 226-14091-2

QUICK Nippilar beinir fyrir nælonrör 6mm

6mm



HEITI	STÆRÐ	VÖRUNÚMER
QUICK Nippill f/nælonrör	6x1mm	317 226-13752-8
QUICK Nippill f/nælonrör	8x1mm	317 226-13752-7
QUICK Nippill f/nælonrör	10x1mm	317 226-13752-6
QUICK Nippill f/nælonrör	1/8"	317 226-13752-9

QUICK Nipplar vinkil fyrir nælonrör 6mm

6mm

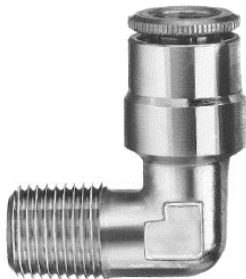

HEITI	STÆRÐ	VÖRUNÚMER
QUICK Nippill f/nælonrör	6x1mm	317 226-13753-7
QUICK Nippill f/nælonrör	8X1mm	317 226-13753-8
QUICK Nippill f/nælonrör	10x1mm	317 226-13753-6
QUICK Nippill f/nælonrör	1/8"	317 226-13753-4

QUICK Snúningsnippill vinkil fyrir nælonrör 6mm

6mm

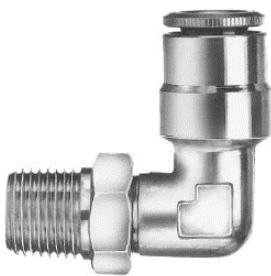

HEITI	STÆRÐ	VÖRUNÚMER
QUICK Snúningsnippill	6x1mm	322 106-111
QUICK Snúningsnippill	8x1mm	322 106-112
QUICK Snúningsnippill	10x1mm	322 106-113
QUICK Snúningsnippill	1/8"	322 106-114

QUICK Té fyrir nælonrör 6mm

6mm



HEITI	STÆRÐ	VÖRUNÚMER
QUICK Té nælonrör 6mm		317 226-14097-2



Quick vinkilsamtengi 6mm nælonrör 322 2015-101

6mm



QUICK Samtengi f/nælonrör 317 226-13773-3

Nippill beinn fyrir 4mm nælonrör

4mm



HEITI	STÆRÐ	VÖRUNÚMER
Nippill f/4mm rör beinn	6x1mm	317 223-12533-5
Nippill f/4mm rör beinn	8x1mm	317 223-12271-8
Nippill f/4mm rör beinn	10x1mm	317 223-13069-1
Nippill f/4mm rör beinn	1/8" R	317 223-12270-8

Nippill vinkil fyrir 4mm nælonrör

4mm



HEITI	STÆRÐ	VÖRUNÚMER
Nippill f/4mm rör vinkill	6x1mm	317 223-12533-6
Nippill f/4mm rör vinkill	8x1mm	317 223-13021-5
Nippill f/4mm rör vinkill	10x1mm	317 223-13069-2
Nippill f/4mm rör vinkill	1/8" R	317 223-13021-4

Samtengi fyrir 4mm nælonrör

4mm



HEITI	VÖRUNÚMER
Samtengi f/4mm rör	317 223-12531-8
Samtengi f/4mm rör í 6mm nælonrör	322 104-000-6

Nippil rær og krumpuhólkur 4 mm

4mm



HEITI	VÖRUNÚMER
Nippil ró fyrir 4mm	317 223-13032-1
Krumpuhólkur fyrir 4mm	317 223-14083-3

Smurslöngur - Nælonslanga 4mm

4mm



HEITI	STÆRÐ	VÖRUNÚMER
Nælonrör feitisfyllt	4 X1,0mm	317 534-36741-3
Nælonrör tómt	4x1,0mm	317 112-35127-7

QUICK Fyrir nælonrör 4 x 1,0 QUICK Fyrir nælonrör 4 x 1,0 QUICK

Úttaksventill QUICK fyrir nælonrör 4mm

4mm

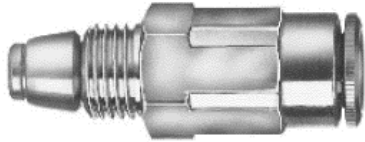

HEITI	STÆRÐ	VÖRUNÚMER
-------	-------	-----------

Úttaksventill QUICK f/nælonrör

QUICK Nippilar beinir fyrir nælonrör 4mm

4mm



HEITI	STÆRÐ	VÖRUNÚMER
-------	-------	-----------

QUICK Nippill f/nælonrör 6x1mm 317 226-13752-3

QUICK Nippill f/nælonrör 8x1mm 317 226-13752-1

QUICK Nippill f/nælonrör 10x1mm 317 226-13752-2

QUICK Nippill f/nælonrör 1/8" 317 226-13752-4

QUICK Nipplar vinkil fyrir nælonrör 4mm

4mm



HEITI	STÆRÐ	VÖRUNÚMER
-------	-------	-----------

QUICK Nippill f/nælonrör 6x1mm 322 104-151

QUICK Nippill f/nælonrör 8X1mm 322 104-152

QUICK Nippill f/nælonrör 10x1mm 322 104-153

QUICK Nippill f/nælonrör 1/8" 317 226-13753-3

QUICK Snúningsnippill vinkil fyrir nælonrör 4mm

4mm

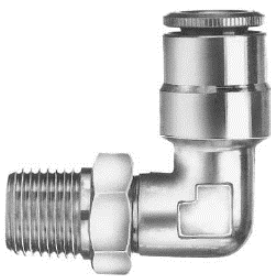

HEITI	STÆRÐ	VÖRUNÚMER
-------	-------	-----------

QUICK Snúningsnippill 6x1mm 317 226-13756-6

QUICK Snúningsnippill 8x1mm 317 226-13756-1

QUICK Snúningsnippill 10x1mm 317 226-13756-2

QUICK Snúningsnippill 1/8" 317 226-13756-3

4mm

HEITI	STÆRÐ	VÖRUNÚMER
-------	-------	-----------

QUICK Samtengi fyrir nælonrörn 4mm

4mm

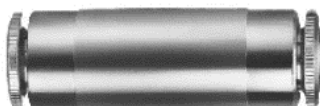

HEITI	STÆRÐ	VÖRUNÚMER
-------	-------	-----------

QUICK Samtengi f/nælonrör 317 226-13773-1

5mm

Nippill beinn fyrir 3/16" (5mm) nælonrör

Fyrir GROENEVELD kerfi



HEITI	STÆRÐ	VÖRUNÚMER
Nippill f/ 3/16" rör beinn	6x1mm	316 65701
Nippill f/ 3/16" rör beinn	8x1mm	316 58501
Nippill f/ 3/16" rör beinn	10x1mm	316 13801
Nippill f/ 3/16" rör beinn	1/8" R	316 10401

5mm

Nippill vinkil fyrir 3/16 (5mm) nælonrör

Fyrir GROENEVELD kerfi



HEITI	STÆRÐ	VÖRUNÚMER
Nippill f/ 3/16" rör vinkill	8x1mm	316 12101
Nippill f/ 3/16" rör vinkill	10x1mm	316 13701
Nippill f/ 3/16" rör vinkill	1/8" R	316 10201

5mm

Samtengi fyrir 3/16" (5mm) nælonrör

Fyrir GROENEVELD kerfi



HEITI	VÖRUNÚMER
Samtengi f/ 3/16" rör (5mm)	316 10601

5mm

Té fyrir 3/16" (5mm) nælonrör

Fyrir GROENEVELD kerfi



HEITI	VÖRUNÚMER
Té f/ 3/16" (5mm)	316 14101

5mm

Nippil rær og krumpuhólkur 3/16" (5mm)

Fyrir GROENEVELD kerfi



HEITI	VÖRUNÚMER
Nippil ró fyrir 3/16" (5mm)	316 15802
Krumpuhólkur fyrir 3/16" (5mm)	316 15801

5mm

Smurslöngur - Nælonslanga 3/16" (5mm)

Fyrir GROENEVELD kerfi



HEITI	STÆRÐ	VÖRUNÚMER
Nælonrör 3/16" (5mm)	3/16" X1,0mm	316 02201

Slönguhólks ró fyrir þrýstislöngu 11,3 X 6,3 FF

11,3mm



HEITI

VÖRUNÚMER

Slönguhólks ró F/11,3

322 100-060

Slönguhólkar fyrir þrýstislöngu 11,3 X 6,3 FF

11,3mm



HEITI

VÖRUNÚMER

SLÖNGUHÓLKUR 6MM F/11,3

322 100-064

SLÖNGUHÓLKUR 8MM F/11,3

322 100-074

SLÖNGUHÓLKUR 10MM F/11,3

322 100-081

11,3mm



HEITI

VÖRUNÚMER

SLÖNGUHÓLKUR 90° 8 MM F/11,3
H23 X L36

322 100-073

SLÖNGUHÓLKUR 90° 10 MM F/11,3
H23 X L36

322 100-083

Samtengi 8mm



HEITI

VÖRUNÚMER

Samtengi f/8mm rör

322 108-000

Smurslöngur - Gúmmí þrýstislanga 11,3mm

11,3mm



HEITI

STÆRÐ

VÖRUNÚMER

Þrýstislanga feitisfyllt
100metrar á rúllunni

11.3X6,3mm

322 100-011

Hlífðarrör plast 8,4

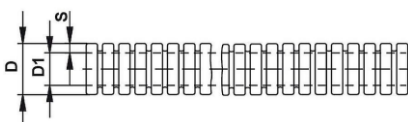

HEITI

STÆRÐ

VÖRUNÚMER

Hlífðarrör plast 8,4

322 100-032

Slönguhólks ró ryðfrí fyrir þrýstislanga 8,4 X 2,1 FF



HEITI

VÖRUNÚMÉR

Slönguhólks ró ryðfrí

322 100-050-VA

Slönguhólkur beinn ryðfrír fyrir 6mm rör

6mm

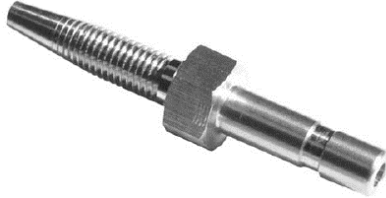

HEITI

VÖRUNÚMÉR

Slönguhólkur beinn standard
ryðfrír

322 100-051-VA

Slönguhólkur boginn ryðfrír 45° fyrir 6mm rör

6mm



HEITI

VÖRUNÚMÉR

Slönguhólkur 45° ryðfrír

322 100-058-VA

Slönguhólkur 90° ryðfrír

322 100-053-VA

Nippill beinn ryðfrír fyrir 6mm nælonrör

6mm



HEITI

STÆRÐ

VÖRUNÚMÉR

Nippill f/6mm rör beinn
Ryðfrír

6x1mm

322 106-001-VA

Nippill f/6mm rör beinn
Ryðfrír

8x1mm

322 106-002-VA

Nippill f/6mm rör beinn
Ryðfrír

10x1mm

322 106-003-VA

Nippill f/6mm rör beinn
Ryðfrír

1/8" R

322 106-004-VA

Nippill vinkil ryðfrír fyrir 6mm nælonrör

6mm



HEITI

STÆRÐ

VÖRUNÚMÉR

Nippill f/6mm rör vinkil
Ryðfrír

6x1mm

322 106-101-VA

Nippill f/6mm rör vinkil
Ryðfrír

8x1mm

322 106-102-VA

Nippill f/6mm rör vinkil
Ryðfrír

10x1mm

322 106-103-VA

Nippill f/6mm rör vinkil
Ryðfrír

1/8" R

322 106-104-VA

6mm

Samtengi ryðfrítt fyrir 6mm nælonrör



HEITI

VÖRUNÚMER

Samtengi f/6mm rör
Ryðfrír

322 106-000-VA

6mm

Nippil ryðfrír, rær og krumpuhólkur 6 mm



HEITI

VÖRUNÚMER

Nippil ró fyrir 6mm
Ryðfrír

322 106-200-VA

Krumpuhólkur fyrir 6mm
Ryðfrír

322 106-210-VA

Framlengingar ryðfríar



< INN

HEITI

LENGD

INNTAK

ÚTTAK

VÖRUNÚMER

Framlenging
Ryðfrí

23mm

1/8" x 1/8"

322 100-148-VA

Uttak

Gegnumtak ryðfrítt fyrir 6mm



HEITI

VÖRUNÚMER

Gegnumtak f/6mm ryðfrítt

317 99998

Plasthettur á smurkoppa

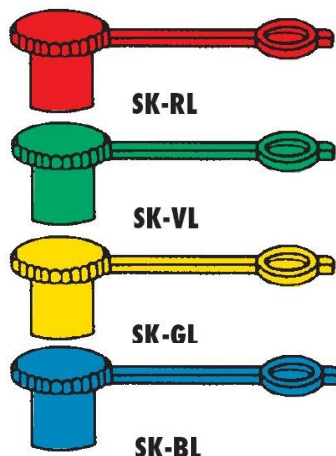

HEITI

VÖRUNÚMER

Plasthetta rauð

305 9500111

Plasthetta græn

305 9500121

Plasthetta gul

305 9500131

Plasthetta blá

305 9500141



Smurkoppur beinir H1



HEITI	STÆRÐ	VÖRUNÚMER
Smurkoppur H1	Std M5 X 0,8	305 1100701
Smurkoppur H1	Std M6 x 1,0	305 1100704
Smurkoppur H1	Std M8 x 1,0	305 1100907
Smurkoppur H1	M8 x 1,25	305 1100908
Smurkoppur H1	Std M10 x 1,0	305 1101109
Smurkoppur H1	M10 x 1,25	305 1101110
Smurkoppur H1	M10 x 1,50	305 1101111
Smurkoppur H1	Std M12 x 1,50	305 1101414
Smurkoppur H1	Std 1/4" UNF-28	305 1100737
Smurkoppur H1	Std 1/2" UNF-20	305 1101440
Smurkoppur H1	Std R1/8" BSP	305 1101156
Smurkoppur H1	Std R1/4" BSP	305 1101457
Smurkoppur H1 Brass	R1/8" BSP	305 1111156
	Ryðfrítt	Ryðfrítt
Smurkoppur H1	V2A M6 x 1,0	305 1120704
Smurkoppur H1	V2A M8 x 1,0	305 1120907
Smurkoppur H1	V2A M8 x 1,25	305 1120908
Smurkoppur H1	V2A M10 x 1,0	305 1121109
Smurkoppur H1	V2A M12 x 1,5	305 1121414
Smurkoppur H1	V2A 1/4" UNF-28	305 1120737
Smurkoppur H1	V2A R1/8" BSP	305 1121156
Smurkoppur H1	V2A R1/4" BSP	305 1121457



Smurkoppur 45° H2



HEITI	STÆRÐ	VÖRUNÚMER
Smurkoppur H2	Std M6 x 1,0	305 1200904
Smurkoppur H2	Std M8 x 1,0	305 1200907
Smurkoppur H2	M8 x 1,25	305 1200908
Smurkoppur H2	Std M10 x 1,0	305 1201109
Smurkoppur H2	M10 x 1,25	305 1201110
Smurkoppur H2	M10 x 1,50	305 1201111
Smurkoppur H2	Std 1/4" UNF-28	305 1200937
Smurkoppur H2	Std 1/2" UNF-20	305 1201440
Smurkoppur H2	Std R1/8" BSP	305 1201156
Smurkoppur H2	Std R1/4" BSP	305 1201457
Smurkoppur H2 Brass	R1/8" BSP	305 1211156
	Ryðfrítt	Ryðfrítt
Smurkoppur H2	V2A M6 x 1,0	305 1220904
Smurkoppur H2	V2A M8 x 1,0	305 1220907
Smurkoppur H2	V2A M8 x 1,25	305 1220908
Smurkoppur H2	V2A M10 x 1,0	305 1221109
Smurkoppur H2	V2A R1/8" BSP	305 1221156
Smurkoppur H2	V2A R1/4" BSP	305 1221457

UMETA

Smurkoppur 90° H3



HEITI	STÆRÐ	VÖRUNÚMER
Smurkoppur H3	Std M6 x 1,0	305 1300904
Smurkoppur H3	Std M8 x 1,0	305 1300907
Smurkoppur H3	M8 x 1,25	305 1300908
Smurkoppur H3	Std M10 x 1,0	305 1301109
Smurkoppur H3	M10 x 1,25	305 1301110
Smurkoppur H3	M10 x 1,50	305 1301111
Smurkoppur H3	Std 1/4" UNF-28	305 1300937
Smurkoppur H3	Std 1/2" UNF-20	305 1301440
Smurkoppur H3	Std R1/8" BSP	305 1301156
Smurkoppur H3	Std R1/4" BSP	305 1301457



Smurkoppur H3 Brass	R1/8" BSP	305 1311156
	Ryðfrítt	Ryðfrítt
Smurkoppur H3	V2A M6 x 1,0	305 1320904
Smurkoppur H3	V2A M8 x 1,0	305 1320907
Smurkoppur H3	V2A M8 x 1,25	305 1320908
Smurkoppur H3	V2A M10 x 1,0	305 1321109
Smurkoppur H3	V2A R1/8" BSP	305 1321156
Smurkoppur H3	V2A R1/4" BSP	305 1321457

UMETA

Smurkoppur þrykktir beinir



HEITI	STÆRÐ	VÖRUNÚMER
Smurkoppur þrykktur	6mm	305 1100186
Smurkoppur þrykktur	8mm	305 1100288
Smurkoppur þrykktur	10mm	305 1100389

UMETA

Smurkoppur skálar D1



INOX V2A



HEITI	STÆRÐ	VÖRUNÚMER
Smurkoppur D1	M6 x 1,0	305 3100724
Smurkoppur D1	M8 x 1,0	305 3100925
Smurkoppur D1	M10 x 1,0	305 3101127
Smurkoppur D1	1/4" UNF-28	305 3100742
Smurkoppur D1	R1/8" BSP	305 3101161
Smurkoppur D1	R1/4" BSP	305 3101462
	Ryðfrítt	Ryðfrítt
Smurkoppur D1	V2A M6 x 1,0	305 3120724
Smurkoppur D1	V2A M8 x 1,0	305 3120925



Smurkoppur flatur 10mm M4



HEITI	HAUS	STÆRÐ	VÖRUNÚMER
Smurkoppur M4 -10mm	M6 x 1,0		305 4201104
Smurkoppur M4 -10mm	M8 x 1,0		305 4201107
Smurkoppur M4 -10mm	M10 x 1,0		305 4201109
Smurkoppur M4 -10mm	R1/8" BSP		305 4201161

Smurkoppur flatur 16mm M1



Smurkoppur M1 -16mm	M8 x 1,0		305 4101707
Smurkoppur M1 -16mm	M10 x 1,0		305 4101709
Smurkoppur M1 -16mm	M12 x 1,5		305 4101714
Smurkoppur M1 -16mm	R1/8" BSP		305 4101761
Smurkoppur M1 -16mm	R1/4" BSP		305 4101762
Smurkoppur M1 -16mm	R3/8" BSP		305 4101763
	Ryðfrítt	Ryðfrítt	
Smurkoppur M1	V2A	M10 x 1,0	305 4121709
Smurkoppur M1	V2A	R1/8" BSP	305 4121761
Smurkoppur M1	V2A	R1/4" BSP	305 4121762

Smurkoppur flatur 22mm

Smurkoppur M22		R1/4" BSP	305 4302262
Smurkoppur M22		R3/8" BSP	305 4302263



Tappar



HEITI	STÆRÐ	VÖRUNÚMER
Tappi	M6 x 1,0	305 5180142
Tappi	M8 x 1,0	305 5180117
Tappi	1/4" UNF-28	305 5180143
Tappi	R1/8" BSP	305 5180122



Smurkoppur langir



HEITI	Lengd	STÆRÐ	VÖRUNÚMER
Smurkoppur 29mm		M6 x 1,0	305 5241060
Smurkoppur 29mm		1/4" UNF-28	305 5241061
Smurkoppur 43mm		R1/8" BSP	305 5241070

UMETA

Smurkoppur niðurfeldir



HEITI	STÆRÐ	VÖRUNÚMER	
Smurkoppur	M8 x 1,0	305 5243010	
Smurkoppur	1/4" UNF-28	305 5243029	
Smurkoppur	Ryðfrítt V2A	Ryðfrítt M8 x 1,0	305 5243069

UMETA

Afloftunarventill



HEITI	STÆRÐ	VÖRUNÚMER
Afloftunarventill	R1/8" BSP	305 5244086

UMETA

Smurkoppur kónískur



HEITI	STÆRÐ	VÖRUNÚMER
Smurkoppur kónískur	M10 x 1,0	305 5310910

UMETA

Ásláttartól fyrir þrykta smurkoppa



HEITI	VÖRUNÚMER
Ásláttartól f/smurkoppa	305 5800058

UMETA

Smurkoppasett



HEITI	VÖRUNÚMER
Smurkoppar- sett 80 stk 6mm-8mm-10mm- R1/8 BSP	305 6008100
Smurkoppar - sett 350 stk 6mm-8mm-10mm- R1/8 BSP - 1/4" BSP Smurstútar líka.	305 6035140
Smurkoppasett 80stk í mm. SEALEY	066 AB008GN



Smursprautur UMETA

HEITI

VÖRUNÚMÉR



Smursprauta 75/PK með röri

305 7721251



Smursprauta 75/PL 600ccm

305 7022212



Smursprauta einhent 85/PK

305 7702211



Smursprauta - Loft DRP30

305 7437505



Smursprauta með brýstimæli

305 9065212



Rör á smursprautur 140mm

305 73110000

Smursprautur Lincoln



Smursprauta fyrir fagmenn lincoln

319 1142



Smursprauta háþrýst lincoln

319 1035



Smursprauta háþrýst löng 600ml.

319 1145



Smursprauta einhent lincoln

319 1133



Áfyllinippill fyrir smursprautu

319 91108

ÁFYLLINIPPILL LINCOLN
Passar við nippil 91108

319 80133

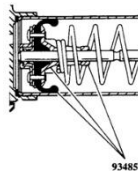

Gúmmí þétting í smursprautu

319 93485

Smursprauta fyrir skrúfaðar túpur
Fínar gengjur. M33 x2,5mm

066 AK4403

**HEITI****VÖRUNÚMER**

Smurbysa fyrir koppafeitisdælu

319 740

Smursprauta 20V Lincoln.**HEITI****VÖRUNÚMER**Smursprauta 20V LI-ION
LINCOLN , 1 batterý og taska.

319 1882-E

Rafhlaða 20V LI-ION F/1882-E
LINCOLN

319 1871

SMURSPRAUTA 18V SEALEY
SEALEY 

066 CPG18V



SMURSLANGA F/ 12-18V SPRAUTU.

066 CPG12V.V2-03

RAFHLAÐA 18V FYRIR CPG18V
SEALEY 

066 CPG18VBP

**Smursprauta - Þrýsti UMETA****HEITI****VÖRUNÚMER**

Smursprauta Þrýsti 30/S 60ccm

305 7130133



Smursprauta Þrýsti 42/S 110ccm

305 7142133



Smursprauta Þrýsti 43/S 110ccm

305 7143133



Smurspruata Þrýsti 44/S 180ccm

305 7144133



Smursprauta Þrýsti 46/S 335ccm

305 7146113

UMETA

Olíusugur



HEITI	VÖRUNÚMER
Olíusuga Tvívirk 250ccm	305 7222702
Olíusuga 500 ccm með slöngu	305 7233912
Olíusuga 1000 ccm með slöngu	305 7244012
Slanga 300mm fyrir olíusugu	305 7277313

Smurstútar



HEITI	VÖRUNÚMER
SMURSTÚTUR LINCOLN 3 ARMA	319 5852
SMURSTÚTUR 4 ARMA 516 G1/8"	305 7351321
SMURSTÚTUR 90° VINKIL G1/8"	305 7351315
SMURSTÚTUR 512/G STÓR G1/8"	305 7351326
SMURSTÚTUR 502/S G1/8"	305 7351121
SMURSTÚTUR 502/H G1/8"	305 7351221
SMURSTÚTUR 502 G1/8"	305 7351421
SMURSTÚTUR 502/NS G1/8"	305 7351521

Veggfestingar fyrir smursprautur



HEITI	VÖRUNÚMER
Smursprautufesting Lincoln	319 G160
Veggfesting fyrir Umeta sprautu	305 VEGG1001

Smurstútur Quick release



HEITI

VÖRUNÚMÉR

SMURSTÚTUR "QUICK RELEASE"

305 9626836

SMURSTÚTUR QUICK RELEASE

066 AK45

Smurnálar



HEITI

VÖRUNÚMÉR

Smurnál LINCOLN 3'

319 5803

Smurnál LINCOLN 6'

319 5806

Smurnál fyrir liðhosur

LX-1416

Smurnál 200XS

305 7321551

Smurstútar



HEITI

VÖRUNÚMÉR

Smurframlenging fyrir Cardan

305 7322451

Flatir hausar fyrir smursprautur



HEITI

VÖRUNÚMÉR

Flatur haus M1 m/quick kúplingu

305 7321651

Flatur haus M10 523 M4

305 7351821

Flatur haus M16 524 M1

305 7351621

Flatur haus M22 525

305 7351721



Snúningsliður "Z" á smurbyssu
1/4-1/4

314 66663

Snúningsliður beinn á smurbyssu
1/4-1/4

314 66661

Smurbarkar

HEITI

VÖRUNÚMER



SMURBARKI M/GORMI 450MM

319 5818



Smurbarki 300mm/1000bar 1/8"

305 7821128



Smurbarki 500mm/1000bar 1/8"

305 7822128



RÖR Á SMURSPRAUTUR 140MM

305 73110000



Snúningur fyrir smursprautu 1/8 -1/8

305 7331921

Olíukönnur

HEITI

VÖRUNÚMER



Smurkanna 200ml

305 7522224

Smurkanna 300ml

305 7523224

Smurkanna 500ml

305 7525224



Olíukanna 1 ltr með loki

066 JDL1

Olíukanna 2 ltr með loki

066 JDL2

Olíukanna 5 ltr með loki

066 JDL5



Olíukanna 2 ltr með stút

066 J2F

Olíukanna 5 ltr með stút

066 J5F



Mælikanna 500ml

066 JM500



Mælikanna 5 lítra

066 JT5000

Trehtar

HEITI

VÖRUNÚMER



TREKT M/FESTI-KLEMMU

066 F12



Trehtar(4) 50/75/95 & 115mm

482 503013



Trekt með Barka 27cm

482 503012



TREKT M/STÚT 180MM OG LOKI

066 F99/180

perma

Perma smurpungar



STAR HYLKI

HEITI	VÖRUNÚMER
UNIVERSAL	
PERMA STAR Hylki universal 60 cm ³ SF01	310 104044
PERMA STAR Hylki universal 120 cm ³ SF01	310 100724
PERMA STAR Hylki universal 250 cm ³ SF01	310 104473
MATVÆLAFEITI NSF H1	
PERMA STAR Hylki matvæla 120 cm ³ SF10	310 100770
KEDJUOLÍA	
PERMA STAR HYLKI 120 cm ³ S014 með keðjuolíu	310 101096
SÉRSTAKLEGA FYRIR LEGUR Í MÓTORA	
PERMA STAR Hylki 60 cm ³ S595	310 106219
PERMA STAR Hylki 120 cm ³ S595	310 104256
HÁHITAFEITI	
PERMA STAR Hylki 120 cm ³ SF03 (310 162003387)	310 100739
VATNSPOLIN FEITI	
PERMA STAR Hylki 120 cm ³ S245	310 16245348
Perma Star Vario Drif Gen.3	310 117222
PERMA STAR Rafhlöður	310 101351
PERMA STAR Viðhaldsró	310 109420

perma

Perma smurpungar



NOVA HYLKI

HEITI	VÖRUNÚMER
UNIVERSAL	
PERMA NOVA Hylki 125 cm ³ SF01	310 110281
HÁPRÝSTIFEITI	
PERMA NOVA Hylki 125 cm ³ SF02	310 110282
HÁHITAFEITI	
PERMA NOVA Hylki 125 cm ³ SF03	310 110283

perma

Perma smurpungar



NOVA HYLKI

HEITI	VÖRUNÚMER
VATNSPOLIN FEITI	
PERMA NOVA Hylki 125 cm ³ OLIT CLS SF245	310 110285
MATVÆLAFEITI	
PERMA NOVA Hylki 125 cm ³ SF10	310 110289
KEÐJUOLÍA	
PERMA NOVA Hylki 125 cm ³ SO14	310 110290
PERMA NOVA Stjórnbox 1-12mån	310 107271

perma

Perma smurpungar



FLEX PLUS HYLKI

HEITI	VÖRUNÚMER
UNIVERSAL	
PERMA FLEX PLUS UNIVERSAL 30cm3 SF10	310 112743
PERMA FLEX PLUS UNIVERSAL 125cm3 SF10	310 111760
HIGH TEMP	
PERMA FLEX PLUS HIGH TEMP 125cm3 SF02	310 111845
MATVÆLAFEITI	
PERMA FLEX PLUS MATVÆLA 125cm3 SF10	310 111852
PERMA FLEX PLUS MATVÆLA 125cm3 H1 SO70 GLÆR	310 111857
KEÐJUOLÍA	
PERMA FLEX PLUS KEÐJUOLÍA 125cm3 SO14	310 111853
UNIVERSAL ELDRI ÚTGÁFA	
PERMA FLEX Hylki 60 cm ³ SF10	310 107224





Perma tappar



FUTURA HYLKI

HEITI		VÖRUNÚMÉR
PERMA TAPPI Gulur	1 Mánuða	310 101331
PERMA TAPPI Grænn	3 Mánuða	310 101332
PERMA TAPPI Rauður	6 Mánuða	310 101333
PERMA TAPPI Grár	12 Mánuða	310 101335
PERMA TAPPI Blár	24 Mánuða	310 20001024
PERMA TAPPI Svartur Frost	1 Mánuð	310 20003055



Aukahlutir fyrir smurpunga



HEITI	VÖRUNÚMÉR
PERMA Klemma universal	310 101388
PERMA CLASSIC JÁRNKLEMMMA	310 26001100
PERMA STAR KLEMMMA A105	310 26001105
PERMA Auka smurunit með loka G1/4"	310 109684
PERMA Plasthylki vörn fyrir Permastar punga.	310 109520
PERMA Nælonrör 8mm	310 101393
PERMA Teflonslanga 8mm 250°C	310 26001260
PERMA SLÖNGUTENGI G1/4" 8MM	310 101496
PERMA SLÖNGUT.SNÚNING G1/4" FYRIR 8MM	310 101497
PERMA SLÖNGUT.SNÚNING G1/8" FYRIR 8MM	310 101571



PERMA PRO Smurpungar

PERMA PRO

HEITI

VÖRUNÚMER



PERMA PRO FEITISHYLKI 250 SF01

310 106639



PERMA PRO FEITISHYLKI 500 SF01

310 106753



PERMA PRO MP-6 COMPLITE
SÉRPÖNTUN

310 106919



PERMA PRO BATTERY B

310 106953



PERMA PRO SNÚNINGSNIPILL 90°
Fyrir 8mm rör 1/8" gengjur

310 27008011



PERMA PRO SNÚNINGSNIPILL 90°
Fyrir 8mm rör 1/4" gengjur

310 27005012



PERMA STAR CONTROL KAPALL
5 METRAR.

310 108432



PERMA Snittmát fyrir koppa og nippla

310 110374



Festingar fyrir perma punga.

HEITI

VÖRUNÚMÉR

PERMA Festing f/1 skammtara
Ryðfrír

310 109663

PERMA Festing f/1 skammtara HD
Ryðfrír

310 109664

PERMA Festing f/2 skammtara
Ryðfrír

310 109667

PERMA Festing f/2 skammtara HD
Ryðfrír

310 108648

PERMA Festing f/3 skammtara
Ryðfrír

310 109670

PERMA Festing f/3 skammtara HD
Ryðfrír

310 109671

PERMA Festing f/4 skammtara
Ryðfrír

310 109673

PERMA Festing f/4 skammtara HD
Ryðfrír

310 109674

PERMA Festing SS A150
Ryðfrír

310 104864

PERMA Festing 50x50x70

310 101429

PERMA Festing 50x70x70

310 101430

PERMA Festing 50x100x70

310 101431

PERMA Festing 110x70

310 101432

HEITI

VÖRUNÚMÉR



PERMA Festistykki brass A151 G1/4" - G1/4"	310 104820
PERMA Framlenging 30mm kopar G1/4" - G1/4"	310 104854
PERMA Framlenging 45mm kopar G1/4" - G1/4"	310 104855
PERMA Framlenging 75mm kopar G1/4" - G1/4"	310 104856
PERMA Framlenging 115mm kopar G1/4" - G1/4"	310 104857
PERMA Hné 45° M6x1 G1/4" - M6x1	310 104824
PERMA Hné 45° M8x1 G1/4" - M8x1	310 104825
PERMA Hné 45° M10x1 G1/4" - M10x1	310 104826
PERMA HNÉ 45° R1/4" G1/4" - G1/4"	310 104823
PERMA Hné 90° M6x1 G1/4" - M6x1	310 260011353 104828
PERMA Hné 90° M8x1 G1/4" - M8x1	310 104829
PERMA Hné 90° M10x1 G1/4" - M10x1	310 104830
PERMA Hné 90° R1/4" G1/4" - G1/4"	310 104827
PERMA Minnkun 1/4" - M6x1 G1/4" - M6x1	310 104837
PERMA Minnkun 1/4" - M8x1 G1/4" - M8x1	310 104838
PERMA Minnkun 1/4" - M8x1,25 G1/4" - M8x1,25	310 104839
PERMA Minnkun 1/4" - M10x1 G1/4" - M10x1	310 104840
PERMA Minnkun 1/4" - 1/8" G1/4" - G1/8"	310 104833
Múffa 1/8" Kopar	7662005
PERMA STÆKKUN 1/4" - 3/8" G1/4" - G3/8"	310 104851
PERMA Brjóstnippill 1/4" G1/4" - G1/4"	310 104852

perma

HEITI

VÖRUNÚMER



PERMA Slöngutengi hún
G1/4" kopar/nickel-plated

310 104821



PERMA Slöngutengi hann kopar
G1/4"

310 104822



PERMA Slöngutengi hún plast
G1/4"

310 26001202



PERMA Slöngutengi hann plast

310 26001203



PERMA Snúningsliði 1/4" 1/4"
G1/4" - G1/4"

310 104831



PERMA T-Stykki 1/4"-1/4"-1/4"
Ryðfrír

310 104850



PERMA Olíuventill A810
G1/4" - G1/4"

310 104862



PERMA Bursti hringlaga 20mm
G1/4"

310 101396



PERMA Bursti 30x40mm
G1/4" (310 26001410)

310 101397



PERMA Bursti 30x60mm
G1/4" (310 26001411)

310 101398



PERMA Busti 30x100mm
G1/4" (310 26001412)

310 101399



Perma slönguendi F/16mm

310 101554



PERMA SLANGA 16X9,5MM

310 101555



Perma slönguendi F/16mm

310 116624

Slot grease smurpungar



HEITI	VÖRUNÚMER
SMURSKAMMTARI SLOTGREASE 100 ml	307 100A
SMURSKAMMTARI SLOTGREASE 220 ml	307 220A

Lubesite smurpungar



HEITI	VÖRUNÚMER
SMURSKAMTARI LUBESITE PLAST 1	308 202
SMURSKAMTARI LUBESITE PLAST 2	308 205
SMURSKAMTARI LUBESITE STÁL 5 O	308 360
KEÐJUGLAS 5 oz FLATUR BURSTI	308 FB5
KEÐJUGLAS 8 OZ FLATUR BURSTI	308 FB8
DROPAGLAS 4 oz	308 G4
DROPAGLAS 5 oz	308 G5
DROPAGLAS 8 oz	308 G8
SJÓNGLAS 3/8"	308 LSPB-38
SJÓNGLAS 1-1/4"	308 LSPB-125
BURSTI RÚNAÐUR 25MM 1/8"	308 803-10

OLÍUDÆLUR

Redashe

HEITI

VÖRUNÚMÉR

OLÍUDÆLA 18V SETT F/20 LTR

313 BOP20-01



DÆLURÖR F/ BOP20 18V
RÖR OG BYSSA FYLGIR MED

313 BP20X-OLA



OLÍUBYSSUR



HEITI

VÖRUNÚMER



**OLÍUBYSSA PLAST M/SLÖNGU & RÖR
1/2"**

314 38025



**OLÍUBYSSA M/DIGITALMÆLI
1/2"**

314 37728



**OLÍUBYSSA ÁL M/SLÖNGU
1/2" 40 Ltr á mín.**

314 38022



**OLÍUSTÚTUR 10 MM 3/8"
AUKASTÚTUR Á OLÍUBYSSU**

314 38015



**OLÍUSTÚTUR 8 MM 3/8"
AUKASTÚTUR Á OLÍUBYSSU**

314 38017



**OLÍUSTÚTUR LANGUR BOGINN 8 MM
AUKASTÚTUR Á OLÍUBYSSU**

314 38018



SLEFBAKKI FYRIR OLÍUBYSSU

314 88630



**HANDDÆLA F/OLÍU + VAGN
VAGN Á FJÓRUM HJÓLUM**

314 30050



**OLÍUDÆLUTANKUR HAND 16 LTR
Athugið, er ekki á hjólum.**

314 32016



**OLÍUDÆLUTANKUR HAND 24 LTR
Er á hjólum.**

314 32024



**OLÍUDÆLUTANKUR LOFT 16 Ltr.
Athugið, er ekki á hjólum.**

314 33016

**OLÍUDÆLUTANKUR LOFT 24 LTR
Er á hjólum.**

314 33024



OLÍUDÆLUTANKUR OG HANDDÆLUR

HEITI

VÖRUNÚMER



OLÍUDÆLUKÚTUR 1 LTR

066 TP6804



OLÍUDÆLUKÚTUR 14 LTR

066 TP16



OLÍUDÆLUKÚTUR 20LTR

066 TP17



**OLÍUÁFYLLINGAR SETT
7 LÍTRA KÚTUR, 1500MM SLANGA**

066 VS7009



OLÍUÁFYLLINGAR MILLISTYKKI

066 VS70090

Mercedes M12 Thread: 722.9 Gearbox
Audi/VW M22 Thread: CVT (Continuously Variable Transmission)
Audi/VW M24 Thread: DSG (Direct-Shift Gearbox)



DÆLUKÚTUR F/SJÁLFSKIPTINGAVÖKVA 3 LTR

066 VS70095



DÆLUKÚTUR F/ GÍROLÍU 5 LTR

066 VS70096



**OLÍUTUNNUÐÆLA M/ARMI
FYRIR 25-210-LTR 0,3 LTR**

066 TP68



OLÍUDÆLA HAND M/SKAFTI RAUÐ

066 TP6803

Fyrir 205ltr tunnur.

DÆLIR 400ML Í HVERRI PUMPU.

Fyrir olíu, frostlög og aðra vökva sem ekki er með ætandi vökva.



OLÍUTUNNUÐÆLA RAFMAGNS

066 TP6818

12 EÐA 230 VOLT

Hentar fyrir til dæmis: Dísel, Adblue , vatn, frostlög.
Rúðvökva, mildar sápur og léttar olíur



OLÍU-BENSÍN OG DIESEL DÆLUR

HEITI	VÖRUNÚMÉR
OLÍUTUNNUDÆLA 12 VOLT M/ SLÖNGU 16ltr/mín 4.5A	066 TP94 12V
OLÍUDÆLA FYRIR 5-20LTR BRÚSA 9 LTR/MÍN 2 stk AA rafhlöður	066 TP80
OLÍUTUNNUDÆLA 24 VOLT M/ SLÖNGU	066 TP9424
OLÍUDÆLA ROTARY 0,3 LTR SNÚN RÖR FYLGIR MEÐ.	066 TP54
Tunnudæla Rotary Olíur, dísel og fl. Rör fylgir með	LX-1318
DÆLA F/BORVÉL 1000 L/KLST 3000 350W - 1/2" KVIKK SLÖNGUENDAR Suitable for water, organic solvents, motor oil, heating oil, insecticides, pesticides, liquid fertilizers and other non-aggressive liquids.	066 TP51
Dæla fyrir borvél heavy duty 2.200 ltr pr hr	066 TP53
BENSÍNDÆLA 12V (4-7 PSI)	102 12S
BENSÍN/DIESELDÆLA 12V1,5-4 PSI	102 FEP-04SV
BENSÍN/DIESELDÆLA 12V 4-7 PSI	102 FEP-06SV



Tunnudæla fyrir ADBLUE

HEITI	VÖRUNÚMÉR
TUNNUDÆLA FYRIR ADBLUE Specially constructed with Viton® seals for transferring AdBlue®. 1" x 2000mm Hose for hands-free applications. Approximately 330ml per stroke discharge. Made in UK.	066 TP6607



SEALEY

HEITI

VÖRUNÚMÉR



OLÍUSÍUTÖNG M/BORÐA 0-300mm

066 AK6403



OLÍUSÍUTÖNG 60-76MM

066 VS6400



OLÍUSÍUTÖNG 73-82mm

066 AK6415



OLÍUSÍUTÖNG 73-85MM

066 VS6401



OLÍUSÍUTÖNG 89-98mm

066 AK6416



OLÍUSÍUTÖNG STILLANLEG
60-120mm

066 AK6419



OLÍUSÍUTÖNG MEÐ KEÐJU
60-105MM

066 VS936



OLÍUSÍUTÖNG 75-95MM

066 AK6420



OLÍUSÍUGREIP 1/2 & 3/8' 65-110

066 AK643



OLÍUSÍUBAND M/HERSLU 65-105 MM

066 AK6441



OLÍUSÍUBOLLI 64,5 X14
TOYOTA

066 VS7111



OLÍUSÍUBOLLI 64,5 X14
LEXUS/TOYOTA

066 VS7112



OLÍUSÍUBOLLI 74,5 X 14 MB
MERCEDES BENS

066 VS7113



OLÍUSÍUBOLLI 87 X14 VOLVO
VOLVO

066 VS7114

SEALEY



HEITI

VÖRUNÚMER

OLÍUSÍUTOPPUR 36 mm 3/8"
BMW, FORD, BENS

066 SX114

OLÍUSÍUBOLLI 74 X 14

066 SX226

AUDI, BMW, CITROEN, FIAT, FORD OG FL.



OLÍUSÍUBOLLASETT (15)

066 VS7003

Size:	Flutes / Steps:
65mm	14 / 1
65-67mm	14 / 2
68mm	14 / 1
73mm	14 / 1
74-76mm	15 / 2
75-77mm	15 / 2
74-76mm	14 / 2
76mm	30 / 1
80mm	15 / 1
82mm	15 / 1
90mm	15 / 1
93mm	15 / 1
93mm	36 / 1
100mm	15 / 1
Adaptor:	3/8" Sq Drive(M) x 1/2" Sq Drive(F)



OLÍUSÍUTOPPASETT (30)

066 VS7006

Adaptor:	3/8" Sq Drive(M) x 1/2" Sq Drive(F)
Size:	Flutes / Steps:
65mm	14 / 1
65-67mm	14 / 2
66mm	6 / 1
68mm	14 / 1
73mm	14 / 1
74mm	15 / 1
74-76mm	15 / 2
75-77mm	15 / 2
76mm	8 / 1
76mm (Shouldered)	12 / 1
76mm	14 / 1
76mm	30 / 1
78mm	15 / 1
80mm	15 / 1
80-82mm	15 / 2
86mm	16 / 1
86mm	18 / 1
90mm	15 / 1
92mm	10 / 1
93mm	15 / 1
93mm	36 / 1
93mm	45 / 1
95mm	15 / 1
96mm	18 / 1
100mm	15 / 1
106mm	15 / 1



Olíusútoppar

HEITI

VÖRUNÚMÉR



OLÍUSÍUPRESSA LOFTKNÚIN

066 HFC08



**OLÍUSÍUPRESSA Á LEGUPRESSU
MAX 115MM**

066 OFC1



MILLISTYKKI FYRIR PRESSU

066 OFCA60



OLÍUTAPPA LYKILL 8 Í EINU
Hex 10mm,12mm,14mm,17mm
Square 3/8, 1/2, 8mm, 10mm

066 VS650



OLÍUTAPPA VIÐGERÐARSETT M13

066 VS613

OLÍUTAPPA VIÐGERÐARSETT M15

066 VS615

OLÍUTAPPA VIÐGERÐARSETT M17

066 VS617

OLÍUTAPPA VIÐGERÐARSETT M20

066 VS620

Olíuaffallstankar



HEITI

VÖRUNÚMER

**OLÍUAFFALLSTANKUR F/GRIFJU
RÚLLAR Á GRIFJUBÖRMUM 65 LTR**

314 42060

OLÍUSOGKÚTUR LOFT 24 LTR

314 43024



HEITI

VÖRUNÚMER

OLÍUSOG & AFFALLSTANKUR 35 L

066 AK456DX

OLÍUAFFALLSTANKUR 65 LTR

066 AK451DX

OLÍUAFFALLS- OG SOGTANKUR 90ltr

066 AK459DX

OLÍUAFFALLSTANKUR 45 LTR
Lár fyrir mótör hjól.

066 AK460DX

BENSÍN SOGTANKUR 40LTR
RYÐFRÍTT STÁL, MAX100PSI
Til að tæma eldsneyti af bílum.

066 TP200S

OLÍUSOGKÚTUR LOFT 9LTR

066 TP6903

SEALEY



HEITI

VÖRUNÚMER

OLÍUSUGA HAND 6.5-LTR

066 TP69

Model No:	TP69
Capacity:	6.5ltr
Suction Probes:	Ø5.8 x 850, Ø6.7 x 850mm
Extension Tubes:	Ø9.8 x 1000mm

OLÍUSOGKÚTUR HAND 9-LTR.

066 TP6901

Model No:	TP6901
Capacity:	9ltr
Suction Probes:	Ø6 x 1100, Ø10 x 1100mm
Extension Tube:	Ø8 x 1100mm

OLÍUSOGKÚTUR HAND 5.5-LTR.

066 TP696

Model No:	TP696
Capacity:	5.5ltr
Suction Probe:	2100mm

**OLÍUSUGA M/ÚTDÆLU
FYRIR ÝMSA VÖKVA**

066 TP501

OLÍUSKOÐUNARSUGA 350ML

066 VS407

Model No:	VS407
Capacity:	350ml
Compatibility:	AdBlue®, Antifreeze, Brake Fluid, Diesel, Oil, Water

SOGDÆLA TVÍVIRK

066 VS560

Model No:	VS560
Hose Size:	Ø13mm x 1mtr (x2), Ø18mm x 1mtr (x2)

SEALEY



HEITI

VÖRUNÚMER

Þynnisdæla f. 25ltr

066 TP99

Model No:	TP99
Drum Suitability:	25ltr
Delivery:	400ml/stroke
Universal Drum Closure	TP99/1
Adaptor (Optional):	

Millistykki f þynnispumpu

066 TP99/1



Olúföt og pallar.

HEITI

VÖRUNÚMER



OLÚFAT 7.6-LTR.
390X120MM

066 DRP02

OLÚFAT 17-LTR.
460X150MM

066 DRP03

OLÚFAT M/ENDURVINNSLU 16-LTR.
460X180MM

066 DRP05

OLÚFAT M/ENDURVINNSLU 54-LTR.
915X660X240MM Er á tveimur hjólum.
Er með niðurfallstappa.

066 DRP09

OLÚFAT FYRIR BRÚSA

066 DRP2030



OLÚSPILLIPALLUR 30 LTR
FYRIR 2 X 25 LTR FÖTUR

066 DRP31



OLÚSPILLIPALLUR 60 LTR
FYRIR 6 X 25 LTR FÖTUR

066 DRP33



TUNNUSTANDUR F/ 2 TUNNUR
1220 X 820 X 330 MM

066 DRP12



TUNNUPALLUR FYRIR 4 TUNNUR
1280 X 1280 X 275 MM

066 DRP13



TUNNU OPNARI

066 TP122



TUNNULYKILL

066 TP127



Tunnumillistykki



HEITI	VÖRUNÚMER
TUNNUMILLISTYKKI F/ PLAST 2" BSP 56MM (MINOR 51MM) 2" INNAN, 56MM UTAN	066 TPA02
TUNNUMILLISTYKKI F/ PLAST 2" BSP 61MM (MINOR 55MM) 2" INNAN, 61MM INNAN	066 TPA07
TUNNUMILLISTYKKI F/ PLAST 2" BSP 55MM (MINOR 51MM) 2" INNAN, 55MM INNAN	066 TPA08
Krani á 20-25 lítra brúsa 61mm Passar á brúsa með 61mm gati	10204
Krani á 200 ltr tunnur fyrir 2"/50mm Passar í stóra tunnugatið	LX-1726
KRANI FYRIR TUNNU 3/4"	066 TP12

Þrýstitankar fyrir olíuþvott



HEITI	VÖRUNÚMER
ÞRÝSTITANKUR F/OLÍUÞVOTT 24LTR ATHUGIN, ER Á HJÓLUM	314 22024
ÞRÝSTITANKUR F/OLÍUÞVOTT 24LTR STAINLESS STEEL F/OLÍU OG SÍRUÞVOTT	314 23024
SPREYBYSSA F/RAASM ÞRÝSTITANK	314 24805
SPREYSTÚTUR	314 24801
SPREYSTÚTUR	314 24802

Koppafeitis áfyllingardætur



HEITI	VÖRUNÚMER
SMURÁFYLLIDÆLA F/KERFI SETT SAMAN Í KASSA 16-30KG	314 60410
QUIK-TENGI F/ ROTORTILT	314 60450
ÁFYLLISTÚTUR HANN	314 60451
SMURDÆLA 50:1 F/ 15-20 KG FÖTU L 410 mm	314 62041
SMURDÆLA 50:1 F/ 20 KG FÖTU L 480 mm F/ CASTROL 18KG	314 62048
SMURDÆLA 50:1 F/ 50 KG TUNNU L 740 mm F/ CASTROL 50KG	314 62074
SMURDÆLA 50:1 F/180 KG TUNNU L 940 mm	314 62095
TUNNULOK 280 MM F/ 15 - 20 KG FÖTUR	314 65280
TUNNULOK 310 MM F/ 20 - 30 KG FÖTUR	314 65310
TUNNULOK 350MM	314 65350
TUNNULOK 385 MM F/ 50 - 60 KG TUNNUR	314 65385
TUNNULOK 600 MM F/ 180-200 KG TUNNUR	314 65600
FYLGIPLATA 265MM F/ 15 - 20 KG FÖTUR	314 66265
FYLGIPLATA 310MM F/ 20 - 30 KG FÖTUR	314 66310
FYLGIPLATA 340MM	314 66340
FYLGIPLATA 370 MM F/ 50 - 60 KG FÖTUR	314 66370
FYLGIPLATA 585 MM F/ 180 - 200 KG FÖTUR	314 66590
SMURBYSSA F/LOFTDÆLU M/Z LIÐ	314 66889



HEITI

VÖRUNÚMER

Snúningsliður "Z" á smurbyssu
1/4-1/4

314 66663



Snúningsliður beinn á smurbyssu
1/4-1/4

314 66661



BRJÓSTNIPPILL 1/4"X 3/8"G M/M

314 66892



VAGN F/20-60 KG FÖTUR 2 HJÓL
STAKUR VAGN.

314 80035



VAGN F/20-60 KG FÖTUR 4 HJÓL

314 80050



VAGN F/200 LTR TUNNU MINNI

314 80200



VAGN F/200 LTR TUNNU STÓR

314 80201



HJÓLAGRIND F/ 205 LTR TUNNUR

066 TP205

Loftslönguhjól



HEITI

VÖRUNÚMER

SLÖNGUHJÓL 8 MM 10 M
INN 3/8" ÚT 1/4"

314 92808.101

SLÖNGUHJÓL 10 MM 8 M
INN 3/8" ÚT 3/8"

314 92808.103

Slönguhjól fyrir olíu



HEITI	VÖRUNÚMER
SLÖNGUJÓL F/OLÍU 150BAR 10M 1/2" M/ SNÚNINGI	314 8420.401
SLÖNGUJÓL F/OLÍU 150BAR 10M 1/2" FÖST VEGGFESTING	314 8430.401
SLÖNGUJÓL F/OLÍU 150BAR 15M 1/2" FÖST VEGGFESTING	314 8430.402
OLÍUSLANGA 1/2" 2 M 150BAR F 1/2" G - F 1/2" G	314 996.302
OLÍUSLANGA 1/2" 4 M 150BAR F 1/2" G - M 1/2" G	314 996.304
OLÍUSLANGA 3/4" 5 M 150BAR F 3/4" G - M 3/4" G	314 997.505

Slönguhjól fyrir koppafeiti



HEITI	VÖRUNÚMER
SLÖNGUJÓL F/KOPPAF. 600BAR 12M 1/4" M/ SNÚNINGI	314 8420.501
SLÖNGUJÓL F/KOPPAF. 600BAR 18M 1/4" FÖST VEGGFESTING	314 8430.502
SMURSLANGA 1/4" X 1,5 M 600BAR F 1/4" G - F 1/4" G	314 993.502
SMURSLANGA 1/4" X 4 M 600 BAR F 1/4" G - M 1/4" G	314 993.504

Slönguhjól fyrir gas og súr

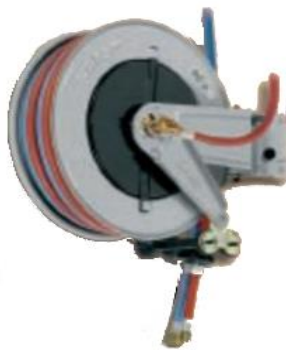

HEITI	VÖRUNÚMER
SLÖNGUJÓL F/GAS&SÚR 20BAR 13M TVÖFÖLD 1/4" SLAGA	314 8420.701
SLÖNGUJÓL F/GAS&SÚR 20BAR 20M TVÖFÖLD 1/4" SLAGA	314 8520.702
SLÖNGUJÓL F/GAS&SÚR 20BAR 25M TVÖFÖLD 1/4" SLAGA	314 8540.701
SLÖNGUJÓL F/GAS&SÚR 20BAR 30M TVÖFÖLD 1/4" SLAGA	314 8540.702

Slönguhjól fyrir vatn



HEITI	VÖRUNÚMER
SLÖNGUJÓL SS/VATN 130° 200BAR 12M 3/8" SVÖRT SLAGA	314 8422.301
SLÖNGUJÓL SS/VATN 130° 200BAR 18M 3/8" SVÖRT SLAGA	314 8422.302
SLÖNGUJÓL SS/VATN 130° 100BAR 25M 1/2" MATVÆLASLANGA BLÁ	314 8523.202
SLÖNGUJÓL SS/VATN 130° 40BAR 17M 3/4" MATVÆLASLANGA BLÁ	314 8543.202



HEITI	VÖRUNÚMER
FÖST VEGGFESTING SLÖNGUJÓL VATN 130°200 BAR 12M 3/8" SVÖRT SLAGA	314 8430.301
SLÖNGUJÓL VATN 130° 200 BAR 18M 3/8" SVÖRT SLAGA	314 8430.302
SLÖNGUJÓL VATN 130° 200 BAR 25M 3/8" SVÖRT SLAGA	314 8530.302
SLÖNGUJÓL LOFT/VATN 20BAR 30M 3/4" FÖST VEGGFESTING Svört gúmmíslanga.	314 8560.101

OVERALL DIMENSIONS

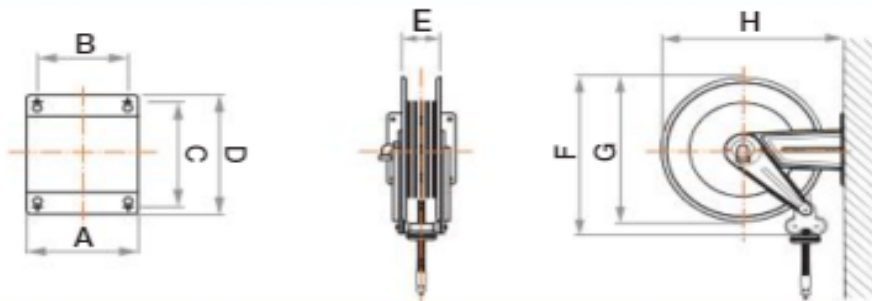

Art.	A	B	C	D	E	F	G	H
S. 390	186	140	196	226	110	400	∅ 390	410
S. 430	186	140	196	226	115	460	∅ 420	460
S. 530	203	153	220	258	115	550	∅ 510	560
S. 540	300	218	228	268	190	550	∅ 510	573
S. 560	488	399	238	272	368	522	∅ 510	578

ACEA gæðaröðun á mótorsmurolium

	Almenn lýsing og notkunarsvið
A/B:	Bensín og dieselvéla smuroliur fyrir fólksbíla
A1/B1	Olíur með seigjustöðugleika, þar sem smurolíuskiptum hefur verið fækkað. Ætluð til notkunar á bensínvélar og dieselvélar í fólksbílum og minni flutingabílum. Þessar olíur henta ekki öllum bílum. Skoðið eigendahandbók sem fylgir með bílnum.
A3/B3	Olíur með seigjustöðugleika, til notkunar í háafkasta bensínvélum og dieselvélum í fólksbílum og minni flutingabílum og eða þar sem olíuskiptum hefur verið fækkað og eða nota á olíu með lágrí seigju og eða við erfiðar aðstæður.
A3/B4	Olíur með seigjustöðugleika, til notkunar í háafkasta bensínvélum og dieselvélum með beinni innspýtingu. Einnig A3/B3
A5/B5	Olíur með seigjustöðugleika, til notkunar þar sem olíuskiptum hefur verið fækkað í háafkasta bensínvélum og dieselvélum í fólksbílum og minni flutningabílum sem geta notað lág-viðnáms/lág-seigju olíu með há-hita/há-skúfunar eiginleikum. Þessar olíur henta ekki öllum vélum. Skoðið eigendahandbók sem fylgir með bílnum.
C:	Olíur samþýðanlegar efnahvötum (í útblásturskerfi)
C1	Olíur með seigjustöðugleika og samþýðanlegar efnahvötum, til notkunar í ökutækjum með sótkornasíum og 3-leiða hvarfakútum í háafkasta bensínvélum og dieselvélum í fólksbílum og minni flutingabílum með lágmarks há-hita/há-skúfunar seigju 2,9 mPa.s. Þessar olíur lengja líftíma sótkornasía og 3-leiða hvarfakúta. Aðvörun: Þessar olíur hafa lægstu brennissteins-/öskumörkin. Skoðið eigendahandbók sem fylgir með bílnum.
C2	Olíur með seigjustöðugleika og samþýðanlegar efnahvötum, til notkunar í ökutækjum með háafkasta bensínvélum og dieselvélum í fólksbílum og dieselvélum í fólksbílum og minni flutningabílum með lágmarks há-hita/há-skúfunar seigju 2,9 mPa.s. Þessar olíur lengja líftíma sótkornasía og 3-leiða hvarfakúta. Aðvörun: Þessar olíur henta ekki öllum vélum. Skoðið eigendahandbók sem fylgir með bílnum.
C3	Olíur með seigjustöðugleika og samþýðanlegar efnahvötum, til notkunar í ökutækjum með háafkasta bensínvélum og dieselvélum í fólksbílum og dieselvélum í fólksbílum og minni flutningabílum með lágmarks há-hita/há-skúfunar seigju 3,5 mPa.s. Þessar olíur lengja líftíma sótkornasía og 3-leiða hvarfakúta. Aðvörun: Þessar olíur henta ekki öllum vélum. Skoðið eigendahandbók sem fylgir með bílnum.
C4	Olíur með seigjustöðugleika og samþýðanlegar efnahvötum, til notkunar í ökutækjum með háafkasta bensínvélum og dieselvélum í fólksbílum og dieselvélum í fólksbílum og minni flutningabílum með lágmarks há-hita/há-skúfunar seigju 3,5 mPa.s. Þessar olíur lengja líftíma sótkornasía og 3-leiða hvarfakúta. Aðvörun: Þessar olíur henta ekki öllum vélum. Skoðið eigendahandbók sem fylgir með bílnum.

ACEA gæðaröðun á mótorsmurolíum

E:	Olíur fyrir þungavinnu-dieselvélar (Heavy Duty)
E1,E2,E3	Ekki lengur í gildi og eru komnir hærra staðlar.
E4	Olíur með seigjustöðugleika sem veita frábæran stimpilhreinleika, slitvörn, sótlosun og smurstöðugleika. Eru ráðlagðar á aflmiklar dieselvélar samv.kröfum Euro I/II/II/IV og V um útblástur og sem starfa við mjög erfiðar aðstæður og t.d. mjög lengdan notkunartíma olíu samkvæmt ráðleggingum framleiðanda. Hentar fyrir EGR (Exhaust Gas Recirculation) vélar, með eða án sótkornasíu og sumar vélar með SCR (Selective Catalytic Reduction) fyrir níturoxíð (Nox). Ráðleggingar geta þó verið mismunandi milli vélaframleiðenda. Skoðið eigendahandbók sem fylgir með bílnum og tækinu.
E6	Olíur með seigjustöðugleika sem veita frábæran stimpilhreinleika, slitvörn, sótlosun og smurstöðugleika. Eru ráðlagðar á aflmiklar dieselvélar samv.kröfum Euro I/II/II/IV og V um útblástur og sem starfa við mjög erfiðar aðstæður og t.d. mjög lengdan notkunartíma olíu samkvæmt ráðleggingum framleiðanda. Hentar fyrir EGR (Exhaust Gas Recirculation) vélar, með eða án sótkornasíu og sumar vélar með SCR (Selective Catalytic Reduction) fyrir níturoxíð (Nox). E6 gæði eru sterklega ráðlögð fyrir vélar með sótkornasíur og eru hannaðar fyrir notkun með lágbrennisteinseldsneyti. Ráðleggingar geta þá verið mismunandi milli vélaframleiðenda . Skoðið eigendahandbók sem fylgir með bílnum og tækinu.
E7	Olíur með seigjustöðugleika sem veita frábæran stimpilhreinleika, og vörn gegn strokkfágun. Að auki frábæra slitvörn, sótlosun og smurstöðugleika. Eru ráðlagðar á aflmiklar dieselvélar samkvæmt kröfum Euro I/II/II/IV og V um útblástur og sem starfa við mjög erfiðar aðstæður og t.d. mjög lengdan notkunartíma olíu samkvæmt ráðleggingum framleiðanda. Henta fyrir vélar án sótkornasíu, og flestar EGR (Exhaust Gas Recirculation) vélar, og flestar vélar með SCR (Selective Catalytic Reduction) fyrir níturoxíð (Nox). Ráðleggingar geta þó verið mismunandi milli vélaframleiðenda. Skoðið eigendahandbók sem fylgir með bílnum og tækinu.
E9	Olíur með seigjustöðugleika sem veita frábæran stimpilhreinleika, og vörn gegn strokkfágun. Að auki frábæra slitvörn, sótlosun og smurstöðugleika. Eru ráðlagðar á aflmiklar dieselvélar samkvæmt kröfum Euro I/II/II/IV og V um útblástur og sem starfa við mjög erfiðar aðstæður og t.d. mjög lengdan notkunartíma olíu samkvæmt ráðleggingum framleiðanda. Henta fyrir vélar án sótkornasíu, og flestar EGR (Exhaust Gas Recirculation) vélar, og flestar vélar með SCR (Selective Catalytic Reduction) fyrir níturoxíð (Nox). E9 gæði eru sterklega ráðlögð fyrir vélar með sótkornasíur og eru hannaðar fyrir notkun með lágbrennisteinseldsneyti. Ráðleggingar geta þó verið mismunandi milli vélaframleiðenda . Skoðið eigendahandbók sem fylgir með bílnum og tækinu.

Samanburður seigjuflokkana (frávik eru mögleg)

Centistokes mm ² /s		SAE flokkanir		ISO VG	AGMA	SUS	
40°C	100°C	Mótor	Gír	Flokkannir	Flokkannir	100°F	210°F
2000	70		250	1500	9	8000	350
1500	60			1000	8A	6000	300
1000	50		140	680	8	5000	250
800	40			460	7	4000	200
600	30	60		320	6	3000	180
500		50	90	220	5	2500	160
400	20			150	4	2000	140
300	18	40	85W	100	3	1500	120
200	16	30		68	2	1000	100
150	14		80W	46	1	800	90
100	12	20		32		600	80
80	10		75W	22		500	70
60	9	10W		15		400	60
50	8	5W				300	55
40	7	0W				250	50
30	6					200	45
20	5					160	40
15	4					140	35
10	3					120	
						100	
						80	
						70	
						60	

Seigjutölur byggðar á einþykktarölum með seigjustuðul (VI) 95. Láréttur samanburður.

SAE flokkanir ákveðnar við 100°C.

SAE W flokkanir eru einnig ákveðnar við ca. -18°C.

ISO og AGMA flokkanir ákveðnar við 40°C.

Breytitafla fyrir seigju miðað við sama hitastig.

Centi-strokes	Saybolt Universal Sek.	Redwood No.1 Sek.	Engler gráður	Centi-strokes	Saybolt Universal Sek.	Redwood No.1 Sek.	Engler gráður
1,8	32	30,8	1,14	96,8	450	397	12,8
2,7	35	32,2	1,18	102,2	475	419	13,5
4,2	40	36,2	1,32	107,6	500	441	14,2
5,8	45	40,6	1,46	118,4	550	485	15,6
7,4	50	44,9	1,60	129,2	600	529	17,0
8,9	55	49,1	1,75	140,3	650	573	18,5
10,3	60	53,5	1,88	151	700	617	19,9
11,7	65	57,9	2,02	162	750	661	21,3
13,0	70	62,3	2,15	173	800	705	22,7
14,3	75	67,6	2,31	183	850	749	24,2
15,6	80	71,0	2,42	194	900	793	25,6
16,8	85	75,1	2,55	205	950	837	27,0
18,1	90	79,6	2,68	215	1000	882	28,4
19,2	95	84,2	2,81	259	1200	1058	34,1
20,4	100	88,4	2,95	302	1400	1234	39,8
22,8	110	97,1	3,21	345	1600	1411	45,5
25,0	120	105,9	3,49	388	1800	1587	51
27,4	130	114,8	3,77	432	2000	1763	57
29,6	140	123,6	4,04	541	2500	2204	71
31,8	150	132,4	4,32	650	3000	2646	85
34,0	160	141,1	4,59	758	3500	3087	99
36,0	170	150,0	4,88	866	4000	3526	114
38,4	180	158,8	5,15	974	4500	3967	128
40,6	190	167,5	5,44	1082	5000	4408	142
42,8	200	176,4	5,72	1190	5500	4849	156
47,2	220	194,0	6,28	1300	6000	5290	170
51,6	240	212	6,85	1405	6500	5730	185
55,9	260	229	7,38	1515	7000	6171	199
60,2	280	247	7,95	1625	7500	6612	213
64,5	300	265	8,51	1730	8000	7053	227
69,9	325	287	9,24	1840	8500	7494	242
75,3	350	309	9,95	1950	9000	7934	256
80,7	375	331	10,7	2055	9500	8375	270
86,1	400	353	11,4	2165	10000	8816	284
91,5	425	375	12,1				

API gírolíuflokkarnir og notkunar svið

API flokkun	Staða flokkunar	Tegund notkunar (almennt)
API GL-1	Í gildi	Til dæmigerðar notkunar á snekkju- og sniglagíra við mildar aðstæður, þar sem óefnabættar smurolíur henta.
API GL-2	Óvirk	Aðstæður venjulegra tengdar snigilgíröxlum, samt erfiðari en GL-1 og þar sem meiri slitvarnar er óskað.
API GL-3	Óvirk	Notkun dæmigerð fyrir snekkjudriföxla og beinskipta gírkassa sem starfa við hóflega erfiðar aðstæður og álag, sem kallar á mild háþrýstibætiefni.
API GL-4	Í gildi	Aðstæður dæmigerðar fyrir „hypoid“ drif sem starfa við hóflegan hraða og álag. Þessar olíur eru einnig notaðar á ýmsa beinskipta gírkassa.
API GL-5	Í gildi	Aðstæður dæmigerðar fyrir „hypoid“ drif sem starfa við mikinn hraða og höggálag, mikinn hraða og lítið álag, lítinn hraða og mikið álag.
API GL-6	Óvirk	Aðstæður dæmigerðar fyrir „hypoid“ drif með hárrí pinnjónsskekkingu. Slík hönnun þarf venjulega aukna vörn gegn rispun, miðað við GL-5.
API MT-1	Í gildi	Háhæfni smurolía fyrir beinskipta þungavinnugírkassa. Í gírolíuþrófinu eru notaðir kúplingsdiskar í samhæfingarkerfi gíra.
API GL-7	Í undirbúningi	Aukin hæfni miðað við GL-5 í „hypoid“ drifum.

ACEA (Association des Constructeurs Européens d'Automobiles) gæða flokkunarkerfi fyrir mótorsmurolíur.

Evrópska flokkunarkerfið CCMC (Committee of Common market Automobile Constructors), var leyst upp 1990 og ASEA stofnað á grunni þess. Meðlimir ACEA eru allir evrópskir bílaframleiðendur. ACEA fæst við breitt svið verkefna, m.a. öryggi, umhverfi og allar reglur sem hafa bein áhrif á evrópska bílaiðnaðinn. ACEA hefur í samvinnu við aðila sem vinna að hönnun smurefna, ásamt mÖrgum fleiri, útbúið samhæft gæðastjórnunarkerfi. Þetta er gert til þess að tryggja að gæðakröfur séu sambærilegar í raun. Einnig að gæðastjórnunarkerfi eina og ISO 9002 geti metið framleiðslu hinna ýmsu bíla- og olíuframleiðenda. Gæðaröðun ACEA hefur tekið við af CCMC röðuninni og gekk formlega í gildi 1.janúar 1996.