



INSTRUCTIONS FOR

## AIR OPERATED BELT SANDER 10 X 330MM

MODEL NO: **SA635**

Thank you for purchasing a Sealey product. Manufactured to a high standard, this product will, if used according to these instructions, and properly maintained, give you years of trouble free performance.

**IMPORTANT:** PLEASE READ THESE INSTRUCTIONS CAREFULLY. NOTE THE SAFE OPERATIONAL REQUIREMENTS, WARNINGS & CAUTIONS. USE THE PRODUCT CORRECTLY AND WITH CARE FOR THE PURPOSE FOR WHICH IT IS INTENDED. FAILURE TO DO SO MAY CAUSE DAMAGE AND/OR PERSONAL INJURY AND WILL INVALIDATE THE WARRANTY. KEEP THESE INSTRUCTIONS SAFE FOR FUTURE USE.



Refer to instructions



Wear eye protection



Wear protective gloves



Wear safety footwear



Wear protective clothing



Wear ear protection



Wear a mask

### 1. SAFETY

- WARNING!** Ensure Health & Safety, local authority, and general workshop practice regulations are adhered to when using this equipment.
- WARNING!** Disconnect from air supply before changing accessories or servicing.
- Maintain the sander in good condition (use an authorised service agent).
- Replace or repair damaged parts. Use genuine parts only. Unauthorised parts may be dangerous and will invalidate the warranty.
- Use in suitable clean and tidy working area, free from unrelated materials and ensure there is adequate lighting.
- Before each use check abrasive belt for condition. If worn or damaged replace immediately.
- Use only the correct size and type of sanding belt with this sander.
- Ensure there are no flammable or combustible materials near the work area.
- WARNING!** Always wear approved eye or face and hand protection when operating the sander.
- Use face, dust, or respiratory protection in accordance with COSHH regulations.
- Depending on the task, sander noise level may exceed 85dB, in which case wear safety ear defenders.
- Remove ill fitting clothing. Remove ties, watches, rings, other loose jewellery and contain and/or tie back long hair.
- Wear appropriate protective clothing and keep hands and body clear of working parts.
- Maintain correct balance and footing. Ensure the floor is not slippery and wear non-slip shoes.
- Keep children and unauthorised persons away from the work area.
- Check moving parts alignment on a regular basis.
- Ensure work piece is secure before operating the sander. Never hold a work piece by hand.
- Check the work piece to ensure there are no protruding screws, bolts, nuts, nails, rivets, etc.
- Avoid unintentional starting.
- WARNING!** Ensure correct air pressure is maintained and not exceeded. Recommended pressure 70-90psi.
- Keep air hose away from heat, oil and sharp edges. Check air hose for wear before each use and ensure that all connections are secure.
- DO NOT** use the sander for a task it is not designed to perform.
- DO NOT** operate sander if any parts are damaged or missing as this may cause failure and/or personal injury.
- WARNING! DO NOT** sand any materials containing asbestos.
- DO NOT** carry the sander by the hose, or yank the hose from the air supply.
- DO NOT** force, or apply heavy pressure to, the sander, let the sander do the work.
- DO NOT** switch the sander on whilst the belt is in contact with the work piece.
- DO NOT** operate sander when you are tired or under the influence of alcohol, drugs or intoxicating medication.
- DO NOT** use sander where there are flammable liquids, solids or gases such as paint solvents and including waste wiping or cleaning rags etc.
- DO NOT** carry the sander with your finger on the power lever.
- DO NOT** direct air from the air hose at yourself or others.
- When not in use disconnect from air supply and store in a safe, dry, childproof location.
- WARNING! LEAD PAINT**  
Paint once contained lead as a traditional ingredient. The dust from the removal of such paint is toxic if ingested / inhaled and must, therefore, be avoided. The following actions must be taken before using the sander on a surface that you suspect may contain lead paint.
  1. User must determine potential hazard relating to age of paint to be removed. (Modern paints do not have lead content).
  2. **DANGER!** Keep all persons and pets away from the work area. The following persons are particularly vulnerable to the effects of lead paint dust: Expectant women, babies and children.
  3. We recommend personal protection by using the following safety items:
    - a) Paint Spray Respirator (Sealey ref. SSP1699)
    - b) PE Coated Hooded Coverall (Sealey ref. SSP265).
    - c) Latex Gloves (Sealey ref. SSP24).
  4. Take adequate measures to contain the paint dust, flakes and scrapings.
  5. Continue to wear safety equipment as in (3) above and thoroughly clean all areas when task is complete. Ensure paint waste is disposed of in sealed bags or containers.

### WARNING! – Risk of Hand Arm Vibration Injury.

This tool may cause Hand Arm Vibration Syndrome if its use is not managed adequately.

This tool is subject to the vibration testing section of the Machinery Directive 2006/42/EC.

This tool is to be operated in accordance with these instructions.

This tool has been tested in accordance with: EN ISO 28927-2:2009 & BS EN ISO 15744:2008.

Declaration and verification of Vibration Emission figures are in accordance with EN 12096:1997

Measured vibration emission value (a): 1.01m/s<sup>2</sup>

Uncertainty value(k): 0.59m/s<sup>2</sup>

Please note that the application of the tool to a sole specialist task may produce a different average vibration emission.

We recommend that a specific evaluation of the vibration emission is conducted prior to commencing with a specialist task.

A health and safety assessment by the user (or employer) will need to be carried out to determine the suitable duration of use for each tool.

NB: Stated Vibration Emission values are type-test values and are intended to be typical.

Whilst in use, the actual value will vary considerably from and depend on many factors.

Such factors include; the operator, the task and the inserted tool or consumable.

NB: ensure that the length of leader hoses is sufficient to allow unrestricted use, as this also helps to reduce vibration.

The state of maintenance of the tool itself is also an important factor, a poorly maintained tool will also increase the risk of Hand Arm Vibration Syndrome.

Health surveillance.

We recommend a programme of health surveillance to detect early symptoms of vibration injury so that management procedures can be modified accordingly.

Personal protective equipment.

We are not aware of any personal protective equipment (PPE) that provides protection against vibration injury that may result from the uncontrolled use of this tool. We recommend a sufficient supply of clothing (including gloves) to enable the operator to remain warm and dry and maintain good blood circulation in fingers etc. Please note that the most effective protection is prevention, please refer to the Correct Use and Maintenance section in these instructions. Guidance relating to the management of hand arm vibration can be found on the HSC website [www.hse.gov.uk](http://www.hse.gov.uk) - Hand-Arm Vibration at Work.

## 2. INTRODUCTION

Aluminium housing with articulated sanding arm. Features belt tracking control, heavy-duty nose roller and one-handed trigger operation. Composite handle with exhaust reduces chill and noise level. Suitable for sanding otherwise inaccessible areas such as around door-shuts. Supplied with three belts. Replacement belts readily available.

## 3. SPECIFICATION

Model No.....	SA635
Belt.....	10 x 330mm
Air Pressure .....	90psi
Air Consumption.....	17cfm
Air inlet.....	1/4" BSP
Weight.....	0.8kg
Noise Pressure Level .....	92.0dBA
Noise Power Level .....	81.0dBA
Vibration level .....	1.01m/s <sup>2</sup>
Uncertainty.....	0.59m/s <sup>2</sup>

## 4. PREPERATION

4.1. **Air Supply** (Recommended hook-up procedure is shown in fig.1.)

4.1.1. Ensure the sander air valve (or throttle) is in the "OFF" position before connecting to the air supply.

4.1.2. You will require an air pressure between 70-90psi, and an air flow of 12cfm.

**WARNING!** Ensure the air supply is clean and does not exceed 90psi. Too high an air pressure and unclean air will shorten the product life due to excessive wear, and may be dangerous causing damage and/or personal injury.

4.1.3. Drain the air tank daily. Water in the air line will damage the sander and will invalidate your warranty.

4.1.4. Clean compressor air inlet filter weekly.

4.1.5. Line pressure should be increased to compensate for unusually long air hoses (over 8 metres). The minimum hose size should be 1/4" I.D. and fittings must have the same inside dimensions.

4.1.6. Keep hoses away from heat, oil and sharp edges. Check hoses for wear, and make certain that all connections are secure.

4.2. **Couplings.**

Vibration may cause failure if a quick change coupling is connected directly to the air sander. To overcome this, connect a leader hose to the sander. A quick change coupling may then be used to connect the leader hose to the air line recoil hose. See figs.1 & 2.

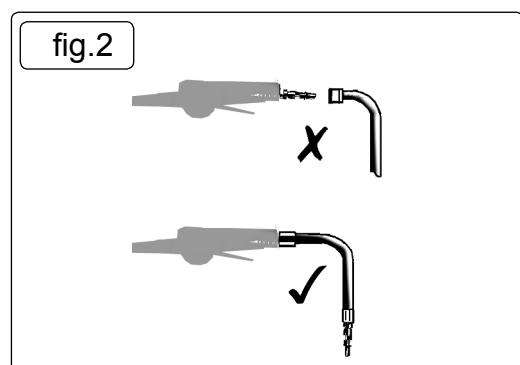
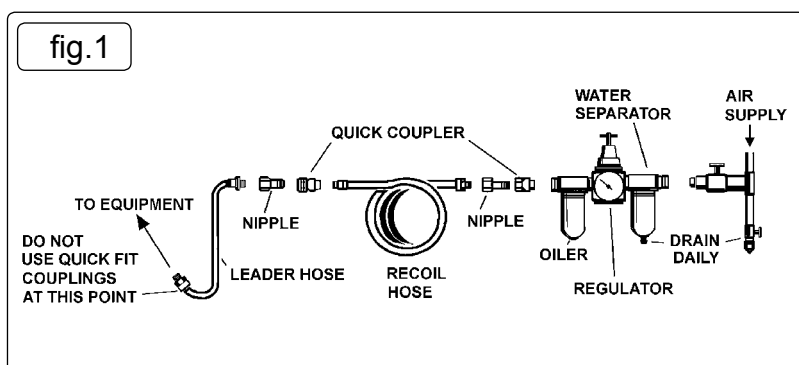

#### 4.3. Belt Preparation

To ensure full flexibility, and to prolong working life, the belt must be “bedded in”

- 4.3.1. Fit new belt ensuring the direction of travel is correct, and the belt join is NOT on the nose roller. Tension belt.
- 4.3.2. Operate the tool without a load applied at half speed for around 10 seconds, then increase to full speed for a further 10 seconds.
- 4.3.3. Finally, at a slow operating speed, using a piece of scrap material, apply light pressure to the belt where it runs over the “shoe”. Increase the operating speed steadily to maximum for a few seconds, then stop.

## 5. OPERATION

- 5.1. Unpack the product and check contents against the parts listed below. If there is anything damaged or missing contact your supplier immediately.  
Contents: a) SA635 Belt Sander.  
b) 3 x Sanding Belt  
c) 2 x Hex. Key
- ☐ **WARNING!** Ensure that you have read and understood the safety instructions in Section 1.
- 5.2. Loosening clamp bolt (fig.3.1. on the top of sander) allows the angle between the grip and the belt to be altered to suit the job in hand. After adjustment tighten the clamp bolt.
- 5.3. Once connected to the air supply the sander is started by squeezing the trigger (2).
- 5.4. To remove and replace the sanding belt push the idle pulley (3) towards the drive pulley (4) against spring pressure. The pulley bracket (5) will retract and lock allowing removal/fitting of the belt. When the new belt is in position release the pulley bracket by pushing in and holding the idle pulley, then press and hold the tension bar (6) whilst releasing the pressure on the idle pulley.
- 4.5 The tracking of the belt can be altered by adjusting cross head screw (7).

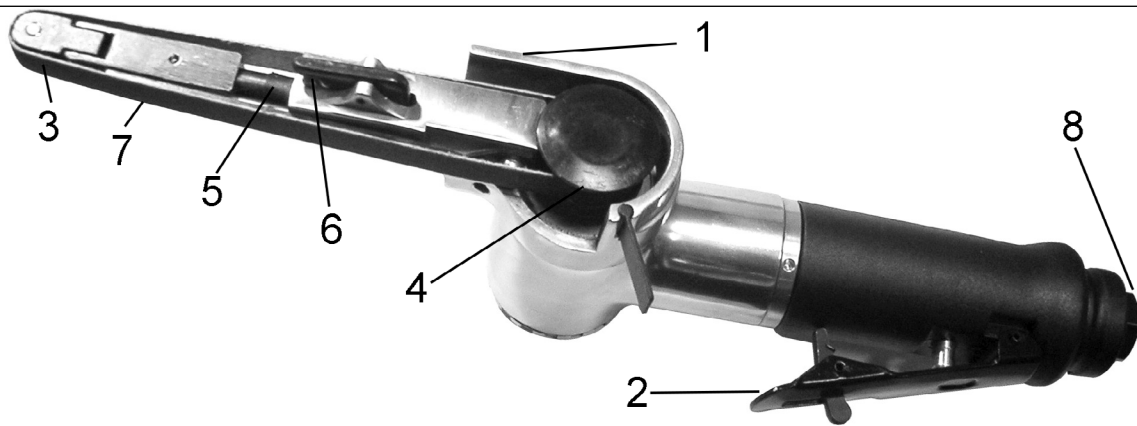

## 6. MAINTENANCE

- ☐ **WARNING!** Disconnect sander from air supply before changing accessories, servicing or performing maintenance. Replace or repair damaged parts. Use genuine parts only. Unauthorised parts may be dangerous and will invalidate the warranty.
- 6.1. If the air supply system does not have an oiler lubricate the sander daily with a few drops of a good grade air tool oil, such as Sealey ATO/500 or ATO/1000, dripped into the air inlet (fig.3.8) before use.
- 6.2. Clean the sander after use and change belt when required.
- 6.3. Loss of power or erratic action may be due to the following:
  - a) Excessive drain on the air supply. Moisture or restriction in the air line. Incorrect size or type of hose connectors. To remedy, check the air supply and follow instructions in Section 3.
  - b) Grit or gum deposits in the sander may also reduce performance. If your model has an air filter (located in the area of the air inlet), remove the filter and clean it. Flush the sander out with gum solvent oil or an equal mixture of SAE No. 10 oil and kerosene. Allow to dry then lubricate before use. If you continue to experience problems, contact your local Sealey service agent.
- 6.4. For a full service contact your local Sealey service agent.
- 6.5. When not in use, disconnect from air supply, clean and store in a safe, dry, childproof location.

Parts support is available for this product. To obtain a parts listing and/or diagram, please log on to [www.sealey.co.uk](http://www.sealey.co.uk), email [sales@sealey.co.uk](mailto:sales@sealey.co.uk) or telephone 01284 757500.



#### Environmental Protection

Recycle unwanted materials instead of disposing of them as waste. All tools, accessories and packaging should be sorted, taken to a recycling centre and disposed of in a manner which is compatible with the environment. When the product becomes completely unserviceable and requires disposal, drain off any fluids (if applicable) into approved containers and dispose of the product and the fluids according to local regulations.

**NOTE:** It is our policy to continually improve products and as such we reserve the right to alter data, specifications and component parts without prior notice.

**IMPORTANT:** No liability is accepted for incorrect use of this product.

**WARRANTY:** Guarantee is 12 months from purchase date, proof of which will be required for any claim.



Sole UK Distributor, Sealey Group.  
Kempson Way, Suffolk Business Park,  
Bury St. Edmunds, Suffolk.  
IP32 7AR



01284 757500



01284 703534



[www.sealey.co.uk](http://www.sealey.co.uk)



[sales@sealey.co.uk](mailto:sales@sealey.co.uk)